



*Power Anytime, Anywhere*

# Tesla™ TI5400 400Hz GPU-24 UAV ACDC Ground Power Unit User Manual



*Built Smart...Proven Tough*

**Tesla Industries, Inc.**  
101 Centerpoint Blvd.  
New Castle, DE 19720  
(302) 324-8910 Phone  
(302) 324-8912 Fax  
[www.teslaind.com](http://www.teslaind.com)  
[www.tesla1.com](http://www.tesla1.com)

# NOTE: All users must read this entire manual prior to operating the TI5400 400Hz GPU-24 UAV ACDC.

The TI5400 400Hz GPU-24 UAV ACDC is a limited maintenance-free and sealed unit. No repairs are authorized. Warranty will be voided if unit is tampered with in any way, or if unauthorized repairs are made. For technical support please contact:

TESLA™ INDUSTRIES INCORPORATED  
101 CENTERPOINT BLVD.  
CENTERPOINT INDUSTRIAL PARK, NEW CASTLE, DELAWARE 19720  
PHONE: (302) 324-8910 FAX: (302) 324-8912  
WEBSITE: [www.teslaind.com](http://www.teslaind.com) ♦ [www.tesla1.com](http://www.tesla1.com) EMAIL: [tesla1@teslaind.com](mailto:tesla1@teslaind.com)



Improper use or failure to follow instructions in this user manual can result in unit damage and/or injury or death by electrical shock.

Any attempts to open or examine the inside of the unit via a tool or device (borescope, probe, etc.) can result in unit failure and/or injury by electrical shock. This GPU is maintenance free and should not be opened or disassembled for any reason.

Always protect the unit from short circuit.

Shipping Hazards: The unit contains sealed, dry cell rechargeable batteries that do not pose a shipping hazard.

All Ground Power Units, Micro Power Units (Aviation Batteries) and including, but not limited to, Battery Chargers/Conditioners, manufactured by Tesla™ Industries, Inc., are able to safely and effectively charge any AGM, Lead Acid battery.

The Tesla™ GPU's and chargers are voltage and current regulated to 0.01% (dual loop). The charging voltage is calibrated, by Tesla™, to 28.6 volts and is pure dc (no power line ripple).

### Maximum Charge Voltage by Battery Type

Type:	Charging Voltage / Cell	Charging Voltage / 12v	Charging Voltage / 24v
SLI/Flooded	2.366v to 2.416v	14.2v to 14.5v	28.4v to 29v
Lead Acid/Flooded	2.366v to 2.416v	14.2v to 14.5v	28.4v to 29v
Sealed Lead Acid	2.366v to 2.416v	14.2v to 14.5v	28.4v to 29v
VRLA	2.366v to 2.416v	14.2v to 14.5v	28.4v to 29v
AGM	2.433v to 2.466v	14.6v to 14.8v	29.2v to 29.6v
GEL	2.350v to 2.400v	14.1v to 14.4v	28.2v to 28.8v

Copyright © 2020 by Tesla™ Industries, Incorporated. All rights reserved.



**SAFETY DATA SHEET**

Form #: SDS 853027  
 Revised: AG  
 Supersedes: AF  
 ECO #: 1002195

<b>I. PRODUCT IDENTIFICATION</b>	
<b>Chemical Trade Name (as used on label):</b> Tesla™ Industries, Inc.	<b>Chemical Family/Classification:</b> Sealed Lead Battery
<b>Synonyms:</b> Sealed Lead Acid Battery, VRLA Battery	<b>Telephone:</b> For information, contact Tesla™ Industries, Inc. Customer Service Department at 302-324-8910
<b>Manufacturer's Name/Address:</b> Tesla™ Industries, Inc 101 Centerpoint Blvd. New Castle, DE 19720-4180	<b>24-Hour Emergency Response Contact:</b> CHEMTREC DOMESTIC: 800-424-9300 CHEMTREC INT'L: 703-527-3877

<b>II GHS HAZARDS IDENTIFICATION</b>		
<b>HEALTH</b>	<b>ENVIRONMENTAL</b>	<b>PHYSICAL</b>
Acute Toxicity (Oral/Dermal/Inhalation) Category 4 Skin Corrosion/Irritation Category 1A Eye Damage Category 1 Reproductive Category 1A Carcinogenicity (lead compounds) Category 1B Carcinogenicity (acid mist) Category 1A Specific Target Organ Toxicity (repeated exposure) Category 2	Aquatic Chronic 1 Aquatic Acute 1	Explosive Chemical, Division 1.3

<b>GHS LABEL:</b>		
<b>HEALTH</b>	<b>ENVIRONMENTAL</b>	<b>PHYSICAL</b>

<b>Hazard Statements</b> <b>DANGER!</b> Causes severe skin burns and serious eye damage. May damage fertility or the unborn child if ingested or inhaled. May cause cancer if ingested or inhaled. Causes damage to central nervous system, blood and kidneys through prolonged or repeated exposure. May form explosive air/gas mixture during charging. Explosive, fire, blast, or projection hazard. May cause harm to breast-fed children Harmful if swallowed, inhaled, or contact with skin Causes skin irritation, serious eye damage.	<b>Precautionary Statements</b> Wash thoroughly after handling. Do not eat, drink or smoke when using this product. Wear protective gloves/protective clothing, eye protection/face protection. Avoid breathing dust/fume/gas/mist/vapors/spray. Use only outdoors or in a well-ventilated area. Contact with internal components may cause irritation or severe burns. Avoid contact with internal acid. Irritating to eyes, respiratory system, and skin. Obtain special instructions before use. Do not handle until all safety precautions have been read and understood Avoid contact during pregnancy/while nursing Keep away from heat./sparks/open flames/hot surfaces. No smoking
---	---

<b>III. COMPOSITION/INFORMATION ON INGREDIENTS</b>		
<b>Components</b>	<b>CAS Number</b>	<b>Approximate % by Weight</b>
<b>Inorganic Lead Compound:</b>		
Lead	7439-92-1	45 - 60
Lead Dioxide	1309-60-0	15 - 25
Tin	7440-31-5	0.1 - 0.2
<b>Sulfuric Acid Electrolyte (Sulfuric Acid/Water)</b>	7664-93-9	15 - 20
<b>Case Material:</b>		5 - 10
Polypropylene	9003-07-0	
Polystyrene	9003-53-6	
Styrene Acrylonitrile	9003-54-7	
Acrylonitrile Butadiene Styrene	9003-56-9	
Styrene Butadiene	9003-55-8	
Polyvinylchloride	9002-86-2	
Polycarbonate, Hard Rubber, Polyethylene	9002-88-4	
Polyphenylene Oxide	25134-01-4	
Polycarbonate/Polyester Alloy	--	
<b>Other:</b>		
Absorbent Glass Mat	--	1 - 2



SAFETY DATA SHEET

Form #: SDS 853027
Revised: AG
Supersedes: AF
ECO #: 1002195

Inorganic lead and sulfuric acid electrolyte are the primary components of every battery manufactured by Tesla™ Products.
There are no mercury or cadmium containing products present in batteries manufactured by Tesla™ Products.

IV. FIRST AID MEASURES

Inhalation:

Sulfuric Acid: Remove to fresh air immediately. If breathing is difficult, give oxygen. Consult a physician
Lead: Remove from exposure, gargle, wash nose and lips; consult physician.

Ingestion:

Sulfuric Acid: Give large quantities of water; do not induce vomiting or aspiration into the lungs may occur and can cause permanent injury or death; consult a physician
Lead: Consult physician immediately.

Skin:

Sulfuric Acid: Flush with large amounts of water for at least 15 minutes; remove contaminated clothing completely, including shoes. If symptoms persist, seek medical attention. Wash contaminated clothing before reuse. Discard contaminated shoes
Lead: Wash immediately with soap and water.

Eyes:

Sulfuric Acid and Lead: Flush immediately with large amounts of water for at least 15 minutes while lifting lids
Seek immediate medical attention if eyes have been exposed directly to acid.

V. FIRE FIGHTING MEASURES

Flash Point: N/A Flammable Limits: LEL = 4.1% (Hydrogen Gas) UEL = 74.2% (Hydrogen Gas)

Extinguishing Media: Carbon dioxide; foam; dry chemical. Avoid breathing vapors. Use appropriate media for surrounding fire.

Special Fire Fighting Procedures:

If batteries are on charge, shut off power. Use positive pressure, self-contained breathing apparatus. Water applied to electrolyte generates heat and causes it to spatter. Wear acid-resistant clothing, gloves, face and eye protection. Note that strings of series connected batteries may still pose risk of electric shock even when charging equipment is shut down.

Unusual Fire and Explosion Hazards:

Highly flammable hydrogen gas is generated during charging and operation of batteries. To avoid risk of fire or explosion, keep sparks or other sources of ignition away from batteries. Do not allow metallic materials to simultaneously contact negative and positive terminals of cells and batteries. Follow manufacturer's instructions for installation and service.

VI. ACCIDENTAL RELEASE MEASURES

Spill or Leak Procedures:

Stop flow of material, contain/absorb small spills with dry sand, earth, and vermiculite. Do not use combustible materials. If possible, carefully neutralize spilled electrolyte with soda ash, sodium bicarbonate, lime, etc. Wear acid-resistant clothing, boots, gloves, and face shield. Do not allow discharge of unneutralized acid to sewer. Acid must be managed in accordance with local, state, and federal requirements. Consult state environmental agency and/or federal EPA.

VII. HANDLING AND STORAGE

Handling:

Unless involved in recycling operations, do not breach the casing or empty the contents of the battery. There may be increasing risk of electric shock from strings of connected batteries. Keep containers tightly closed when not in use. If battery case is broken, avoid contact with internal components. Keep vent caps on and cover terminals to prevent short circuits. Place cardboard between layers of stacked automotive batteries to avoid damage and short circuits. Keep away from combustible materials, organic chemicals, reducing substances, metals, strong oxidizers and water. Use banding or stretch wrap to secure items for shipping.

Storage:

Store batteries in cool, dry, well-ventilated areas with impervious surfaces and adequate containment in the event of spills. Batteries should also be stored under roof for protection against adverse weather conditions. Separate from incompatible materials. Store and handle only in areas with adequate water supply and spill control. Avoid damage to containers. Keep away from fire, sparks and heat. Keep away from metallic objects which could bridge the terminals on a battery and create a dangerous short-circuit

Charging:

There is a possible risk of electric shock from charging equipment and from strings of series connected batteries, whether or not being charged. Shut-off power to chargers whenever not in use and before detachment of any circuit connections. Batteries being charged will generate and release flammable hydrogen gas. Charging space should be ventilated. Keep battery vent caps in position. Prohibit smoking and avoid creation of flames and sparks nearby. Wear face and eye protection when near batteries being charged.

VIII. EXPOSURE CONTROLS/PERSONAL PROTECTION

Exposure Limits (mg/m3) Note: N.E.= Not Established

Table with 7 columns: INGREDIENTS (Chemical/Common Names), OSHA PEL, ACGIH, US NIOSH, Quebec PEV, Ontario OEL, EU OEL. Rows include Lead and Lead Compounds, Tin, Sulfuric Acid Electrolyte, Polypropylene, Polystyrene, Styrene Acrylonitrile, Acrylonitrile Butadiene, Styrene, Styrene Butadiene, Polyvinylchloride.

For expanded detailed info, download the PDF online at...
http://www.teslaind.com/PDF/chart/Tesla-Safety-Data-Sheet.pdf.



# Table of Contents

Section 1 – Safety Review	1
1.1 – Safety Notices	1
1.2 – Symbols	1
1.3 – Hazards	2
1.4 – Important Safety Precautions	2
1.5 – Extreme Environments	3
Section 2 – Product Overview	4
2.1 – Introduction	4
2.2 – Abbreviations	5
2.3 – TI5400 400Hz GPU-24 UAV ACDC Front View	6
2.4 – TI5400 400Hz GPU-24 UAV ACDC Side View	7
Section 3 – Unit Specifications	8
3.1 – General Specifications	8
3.2 – Physical Dimensions	9
3.3 – Airflow Ports	9
3.4 – Block Diagram	10-11
3.5 – Engine Starting Power	12
Section 4 – Features Overview	13
4.1 – 3-Phase 60Hz AC Input Cable Assembly and Cable Extension	13
4.2 – 60Hz 3-Phase AC Input Circuit Breaker	14
4.3 – Inverter Input Power Switch	14
4.4 – DVAM Interface Receptacle	15
4.5 – Digital Volt/Amp Meter (TI300A DVAM)	15
4.6 – DC Output “ON” and “OFF” buttons	16
4.7 – DC Output Receptacle	16
4.8 – “Push to Test” Button and LED Charge Status Meter	17
4.9 – 400Hz AC Input	18
4.10 – 400Hz AC Input Circuit Breaker	18-19
4.11 – 400Hz AC Input Interlock Lamp	19
4.12 – 400Hz Interlock Breaker	19
4.13 – 400Hz Surge/EMC Filter	20
4.14 – 400Hz 200 Y 115 Vac Output	20
4.15 – 400Hz AC Output Circuit Breaker and Power Indicator	21
4.16 – Inverter Display Panel	21
4.17 – Inverter On/Off Switch	22
4.18 – 60Hz 120 Vac Power Outlet and Circuit Breaker	22
4.19 – Telescopic Handle	23
4.20 – Removable Tires	23
4.21 – Air Exhaust Fans	24

Section 5 – Pre-Operation Procedures	25
5.1 – Temperature Specifications	25
5.2 – Unit Charging	26-27
5.3 – Maintenance Check	27
5.4 – Checking Cell Capacity	27
Section 6 – Operating Procedures	28
6.1 – Operating Overview	28
6.2 – Regulated 30.25 Vdc Output Ground Power	28-29
6.3 – 400Hz 200 Y 115 3-Phase 30 AMP Vac	30-31
6.4 – 60Hz 120 Vac Power Outlet	32-34
Section 7 – Post Operation	35
7.1 – After Operating	35
7.2 – Power Cell Recharging	35
Section 8 – Unit Care and Maintenance	36
8.1 – Unit Care	36
8.2 – Normal Function Test Procedures	37-41
8.3 – Unit Servicing	41
8.4 – Packaging and Shipping	42
8.5 – Storage	42
Section 9 – Optional Accessories	43
9.1 – Rain/Dust Cover	43
9.2 – Shipping Case	43
9.3 – Customized Cables	44
9.4 – Cobra™ DC Aviation Plug Replacement Contacts and Tools	44
9.5 – Tow Cart	44
Section 10 – Frequently Asked Questions	45-46
Section 11 – Troubleshooting	47-51
Section 12 – Performance Data	52
12.1 – Purpose	52
12.2 – Explanation of Data	52
12.3 – General Conditions	52
12.4 – Definitions of Abbreviations	52
12.5 – Performance Graphs	53
12.6 – Temperature Conversion Chart	54
Glossary	55
Repair Request Form	57

## Reporting Errors and Recommending Improvements

You can help improve this publication. If you find any mistakes, or if you know of a way to improve these procedures, please let us know.

Send your recommendations to

Tesla™ Industries Inc.

101 Centerpoint Blvd

New Castle Delaware 19720.



or

E-mail directly to [tesla1@teslaint.com](mailto:tesla1@teslaint.com).

# Section 1 – Safety Review

## 1.1 - Safety Notices

Safety notices appear throughout this manual to alert the user to important information regarding proper installation, operation, maintenance and storage of the unit. These notices, as illustrated below, contain a key word that indicates the level of hazard and a triangular icon that indicates the specific type of hazard.

 <b>WARNING</b>	Indicates a condition, operating procedure or practice, which if not adhered to could result in serious injury or death.
 <b>CAUTION</b>	Indicates a condition or operating procedure, which if not strictly adhered to could result in damage or destruction of equipment.
 <b>NOTE</b>	Indicates a condition, operating procedure or practice, which is essential to highlight.

## 1.2 - Symbols

The following symbols will appear within the warning triangles to alert the user to the specific type of danger or hazard.



Figure 1.2.1 – Different types of hazard and caution symbols

## 1.3 – Hazards

**WARNING****Shock Hazard Potential**

Severe injury or death from electrical shock may occur, if either user or the unit is wet, while the unit is connected to a power source. If the unit has come into contact with water, disconnect ac power from the ac source. If AC Input Circuit Breaker has tripped due to water infiltration, DO NOT try to reset it with the ac line voltage attached.

**WARNING****Shock Hazard Potential**

Severe injury or death from electrical shock can occur when damp electrical plugs are connected to the unit. Before making any connections, turn off unit. Failure to use proper grounding can cause potential shock hazard! In different countries, the power cord may require the use of a plug adapter to achieve plug style compatibility for operation. Use only adapters with proper grounding mechanism.



Figure 2.3.1 – Proper plug for 60 Hz three phase.

## 1.4 – Important Safety Precautions

**WARNING****Fire/Explosion Hazard Potential**

Severe injury or death from fire or explosion can occur if electrical sparks are produced near fuel vapors. DO NOT CONNECT ac power supply WHILE FUELING. AC power functions of unit shall not be operated during any fuel handling operation. Power output is restricted to dc power only.

## 1.5 – Extreme Environments



### CAUTION

Unit Damage Potential

The unit's charger temperature switch automatically disables the unit when the internal temperature exceeds 150°F (65°C). This protects the unit from overheating and damage. If the unit shuts down, move the unit into a cooler environment such as shade or air conditioning when possible. Perform a full function test, after the unit has been allowed to cool, prior to use.



### WARNING

Operating any electrical equipment in the presence of moisture creates possible safety hazards and/or potential for equipment damage. Every effort has been made, within the scope of existing technology to prevent foreseeable safety hazards and make the unit moisture resistant to prevent damage or failure.

In the event of the presence of moisture, preventive measures and precautions shall be taken to:

- A. Prevent accumulation of moisture on ac and dc connectors/receptacles
- B. Minimize moisture entering forward inlet and outlet cooling fan vent ports

Unit inlet and outlet vent ports shall be covered from exposure. Unit shall be kept horizontal. It is recommended that the TI7000-083 Protective Rain Cover (see Section 9) be fitted onto the Unit to guard it from moisture. The limits and operational constraints listed below shall apply for the following environmental (weather) conditions:

Conditions	With Raincover	Without Raincover
<b>Heavy or steady rain:</b> <i>Precipitation falling with an intensity in excess of 0.30 inch (0.76 cm) or continuously between 0.30 and 0.10 inch per hour.</i>	OK	OPERATION NOT RECOMMENDED
<b>Light rain, drizzle or sleet:</b> <i>Precipitation falling on a continuous basis between 0.10 inch and less than 1/50 inch (0.5 mm) per hour</i>	OK	DC OPERATIONS ONLY
<b>Heavy or steady snow:</b> <i>Generally meaning an accumulation between 4 inches and less than 1 inch in a 12 hour period.</i>	OK	OPERATION NOT RECOMMENDED
<b>Light snow:</b> <i>Snow falling intermediately with little or no accumulation.</i>	OK	DC OPERATIONS ONLY
<b>Fog:</b>	OK	OK



# Section 2 – Product Overview

## 1.2 – Introduction

This manual contains the complete operating instructions and procedures for the TI5400 400Hz GPU-24 UAV ACDC. The Tesla™ TI5400 series GPU has been designed to serve as a single source of power for the Global Hawk UAV as well as other UAV systems. Using a 30 kVA 3-phase 400 Hz Generator, the TI5400 400Hz GPU-24 UAV ACDC provides (a) protected and filtered 400 Hz 3-phase output power up to 30 amps for aircraft systems, (b) 30.25 Vdc 400 amp continuous regulated dc output voltage, and (c) a convenient ac power outlet that can be used to plug in a laptop computer, test equipment, and other electronic devices.

The unit's high-capacity power cells and circuitry are encased in a rugged enclosure. This internal circuitry incorporates an intelligent recharging system that allows the GPU to rapidly recharge from either a 3-phase 208 Vac 50/60 Hz or 3-phase 200 Y 115 Vac 400 Hz power source. The unit also comes equipped with independent controls for each output (Circuit Breakers, ON/OFF Buttons), an LCD readout for Inverter function, and a built-in Charge Status Meter (via the "Push to Test" button) that also serves as a recharge state indicator for the dc output. Additionally the GPU includes a 25' DC Aviation Cable Assembly (TI2007-425) or a 15' DC Aviation Cable Assembly (TI2007-415), a 3-Phase Extension Cable with 460 P9W (TI2000-070), a 400 Hz Interface Cable (TI2006-309), and a TI3100A DVAM (Digital Volt/Amp Meter) with a TI2006-001 DVAM Interface Line Cord.



Figure 2.1.1 – TI5400 400Hz GPU-24 UAV ACDC

## 2.2 – Abbreviations

The following is a list of commonly used abbreviations found throughout this manual.

### **Abbreviation**   **Definition**

ac	Alternating Current
AFT	Airflow Technology
AWG	American Wire Gauge
amp or A	Ampere
cont	Continuous
°C	Degree Celsius
°F	Degree Fahrenheit
dc	Direct Current
EFF	Efficiency
ft	Feet
FWD	Forward
GPU	Ground Power Unit
Hr	Hour
Hz	Hertz
kg	Kilograms
kHz	Kilohertz
kW	Kilowatts
LED	Light Emitting Diode
max	Maximum
MΩ	megaohm
min	Minimum
MPU	Micro Power Unit
NEMA	National Electrical Manufacturers Association
Ω	ohm
PF	power factor
PFC	power factor correction
rms	root-mean-square
THD	Total Harmonic Distortion
TMDE	Test, Measurement, & Diagnostic Equipment
UAV	Unmanned aerial vehicle
Vac	Volts, Alternating Current
Vdc	Volts, Direct Current
W	watts

## 2.3 – TI5400 400Hz GPU-24 UAV ACDC Front View

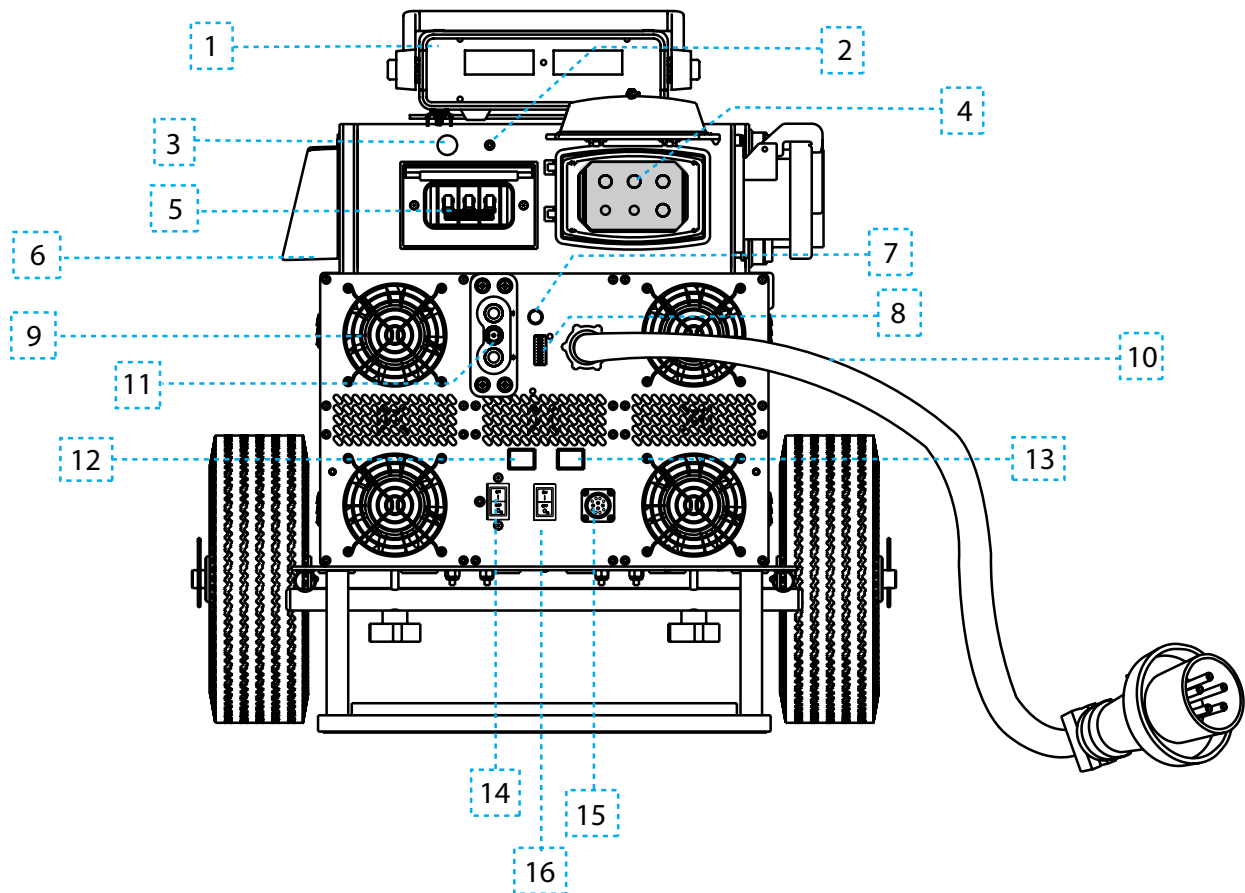

- 1. TI3100A DVAM (Digital Volt/ Amp Meter)** – Provides measurements for dc voltage from 1 to 100 V and dc current up to 2000 amps for aircraft and vehicle.
- 2. 400 Hz Input Interlock LED** – Indicates unit is connected to 400 Hz power.
- 3. 400 Hz Interlock Breaker** – Protects internal Interlock circuitry from potential shorts in the 400 Hz Cable or external equipment.
- 4. 400 Hz AC Input** – Receptacle for 400 Hz 200 Y 115Vac 3-phase input power.
- 5. 400 Hz Input Circuit Breaker** – Protects the GPU from any power surges.
- 6. Inverter Fan** – Provides active cooling for Inverter.
- 7. “Push to Test” Button** – Displays current battery charge state when pressed.
- 8. LED Charge Status Meter** – Indicates battery charge state/power output status.
- 9. Air Inlet Fan** – Provides active cooling for internal components.
- 10. 60 Hz 3-phase AC Input Cable** – Used for 60 Hz 3-phase 208-240 Vac input power.
- 11. DC Output Receptacle** – Provides output of 30.25 Vdc @ 400 A (3000 A peak).
- 12. DC Output ON Button** – Engages the DC Output Receptacle.
- 13. DC Output OFF Button** – Disengages the DC Output Receptacle.
- 14. 60 Hz AC Inverter Power Switch** – Enables/ Disables 120 Vac Inverter.
- 15. DVAM Interface Receptacle** – Allows direct connection of Tesla™ DVAM.
- 16. 60 Hz Input Circuit Breaker** – Protects the GPU from any power surges.

## 2.4 – TI5400 400Hz GPU-24 UAV ACDC Side View

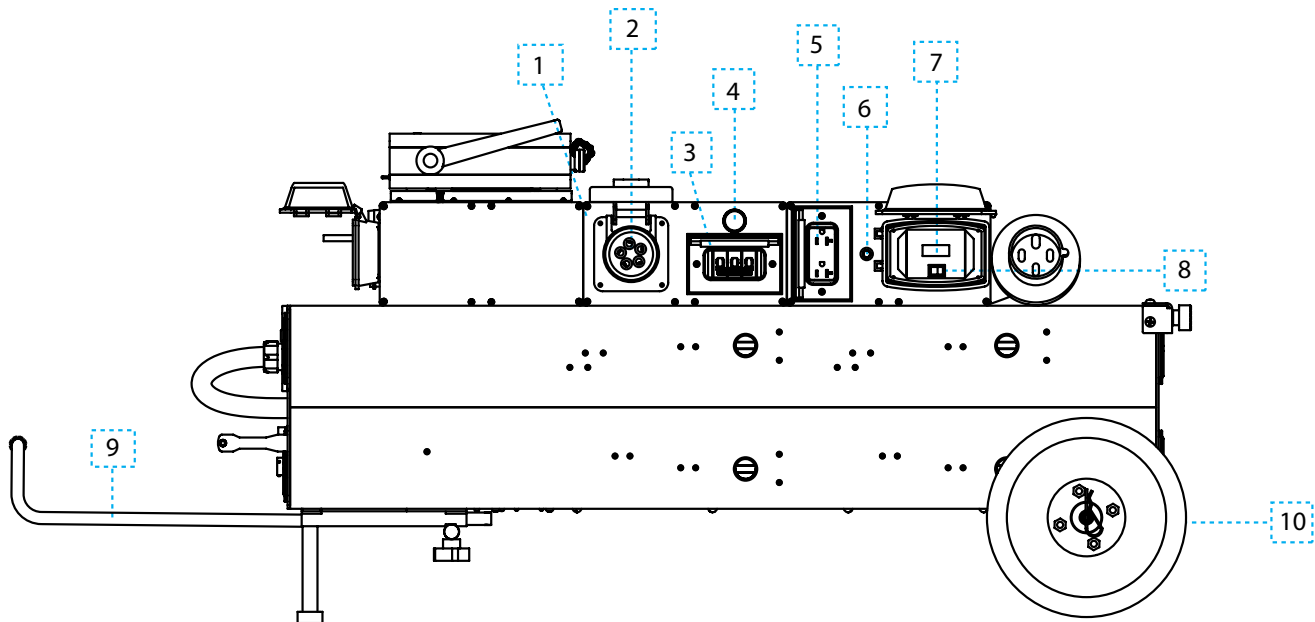

1. **400 Hz Surge/EMC Filter** – Filters 400 Hz input and ports to 400 Hz Output.
2. **400 Hz 200 Y 115 AC Output** – Provides output of 200 Y 115 Vac @ 30 A when active.
3. **400 Hz Output Circuit Breaker** – Enables/disables 400 Hz output.
4. **400 Hz Output Power Indicator** – Indicates that power is present at 400 Hz output.
5. **60 Hz 120 Vac Power Outlet** – Provides output of 120 Vac @ 15 A when active.
6. **Inverter Output Circuit Breaker** – Trips if Inverter output exceeds 20A.
7. **Inverter Display Panel** – Indicates input voltage and current, and output power.
8. **Inverter On/Off Switch** – Enables/disables Inverter Output.
9. **Telescopic Handle** – Allows easy transport and maneuvering of unit.
10. **Removable Run-Flat Tires** – Solid foam rubber tire easily removable for replacement.

# Section 3 – Unit Specifications

## 3.1 – General Specifications

### Electrical

---

#### DC Output Power:

- 3000 peak starting amps
- 400 amps continuous @ 30.25 Vdc - 12100 Watts (when plugged into ac power)
- 446 amp hours (12,424 watt hours) with three-phase ac power
- 46 amp hours (1,024 watt hours) of rechargeable battery power without three-phase ac

#### Rechargeable Rate:

- 12 minutes (from full discharge) with 208-240 Vac power, three-phase @ 25 °C

#### AC Input Power:

- Operates and charges from either three-phase 200-260 Vac 50/60 Hz or three-phase 200 Y 115 Vac 400 Hz.
- 42 amps @ 208 Vac 50/60 Hz - 8736 Watts
- 75 amps @ 200 Vac 400 Hz - 1500 Watts
- Requires 60 amp service for 50/60 Hz (contact Tesla™ for receptacle information)
- Requires 100 amp service for 400 Hz (contact Tesla™ for receptacle information)

#### 2 kW AC Inverter:

- 1800 watts
- 120 Vac 60 Hz Pure Sine Wave <3% THD.
- 15 amps output
- Surge 2900 watts
- Dual GFI receptacle

#### Inverter Operating Temperature:

- -20 °C to 65 °C (-4 °F to 150 °F)

#### Inverter Storage Temperature:

- -40 °C to 65 °C (-40 °F to 150 °F)

#### Power Cell:

- Dry, High Rate Discharge, Rechargeable , Maintenance-free

#### Physical Properties:

- Size: 50" L x 22.75" W x 21" H (24.655" H with DVAM attached)
- 1270mm x 577.85mm x 533.40mm (625.47mm with DVAM attached)
- Weight: 292 lbs (132.4 kg)

#### GPU Operating Temperature:

- -40 °C to 60 °C (-40 °F to 140 °F) without ac power
- -40 °C to 55 °C (-40 °F to 131 °F) with ac power

#### GPU Storage Temperature:

- -65 °C to 105 °C (-85 °F to 221 °F)

#### Cell Capacity:

- +40 °C      110%    ± 05%
- +25 °C      100%    ± 05%
- +00 °C      80%     ± 05%
- -20 °C      65%     ± 10%
- -40 °C      50%     ± 10%

### 3.2 – Physical Dimensions

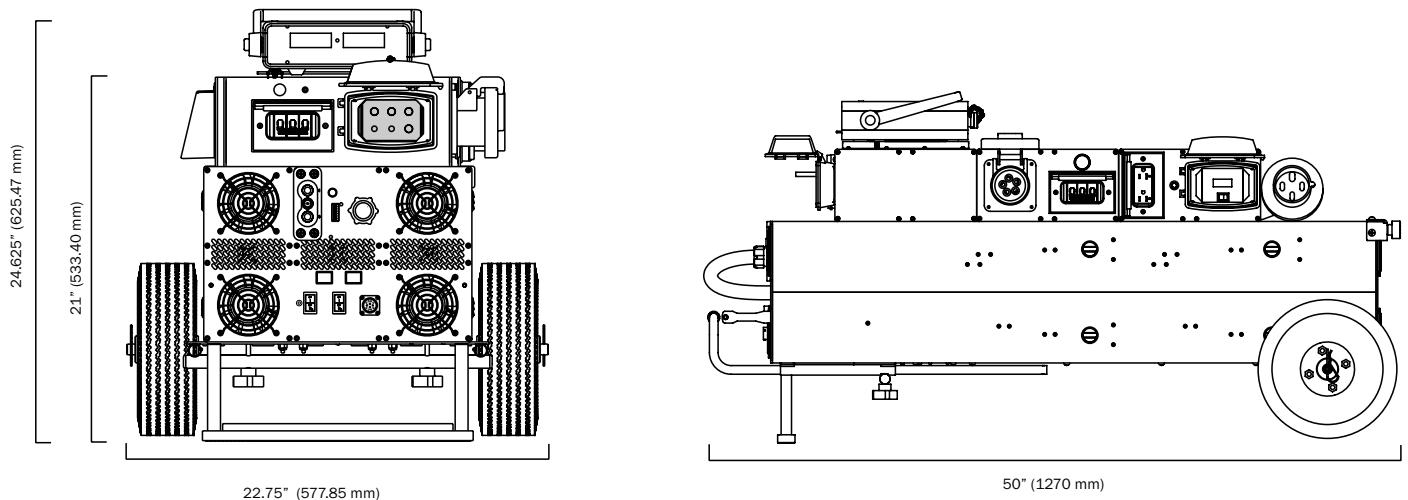

Figure 3.2.1 – TI5400 400Hz GPU-24 UAV ACDC physical dimensions

### 3.3 – Airflow Ports



#### CAUTION

Damage may occur if the unit's air intake or outlet ports are obstructed. Ensure that ports are clear at all times.

When the unit is plugged into ac power, the internal cooling system will efficiently regulate unit temperature regardless of load. At room temperature (+77 °F) the exhaust air will not exceed the ambient temperature by more than 5 °F. In more extreme temperatures (greater than 90 °F) the exhaust air will not exceed the ambient temperature by more than 10 °F.

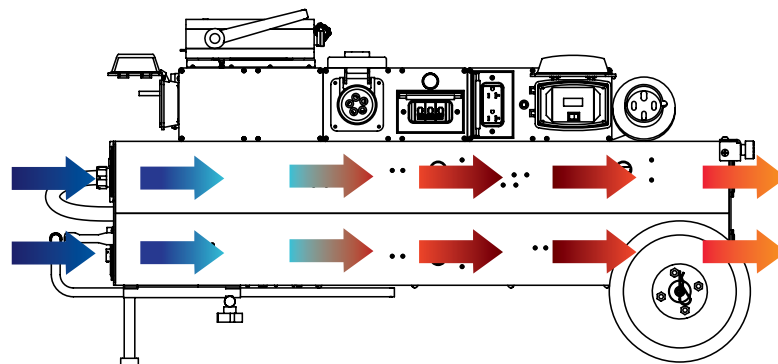
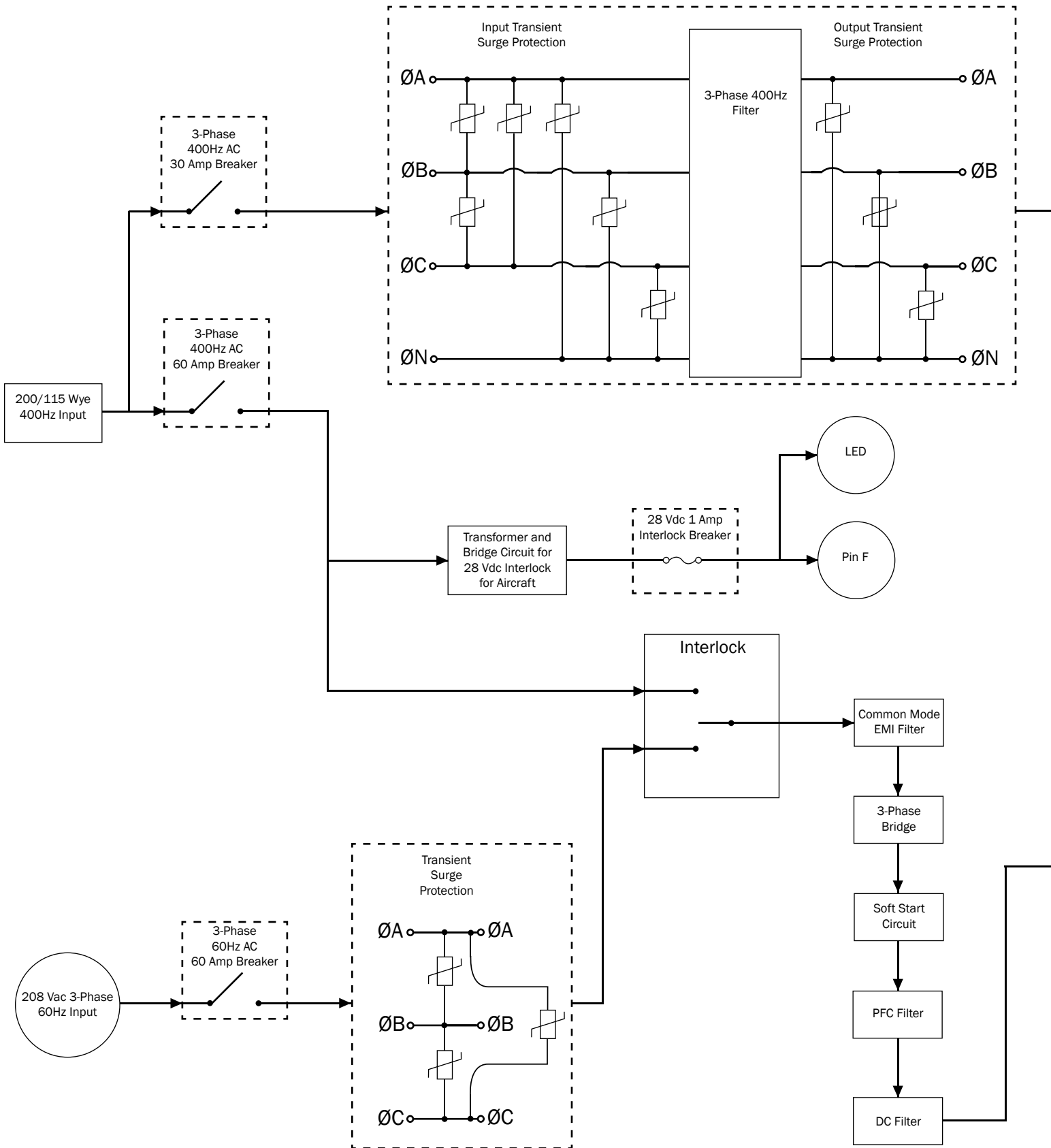
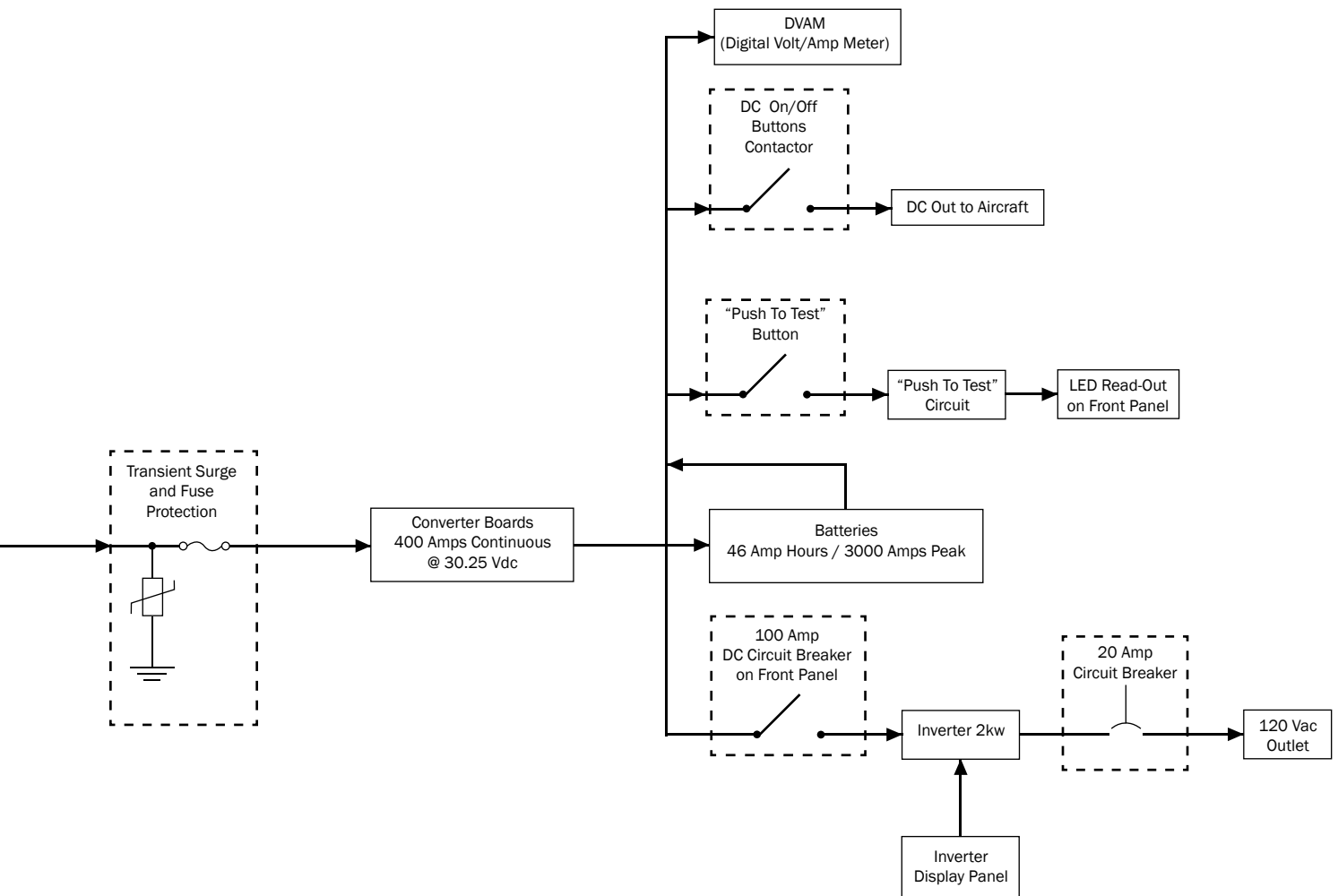
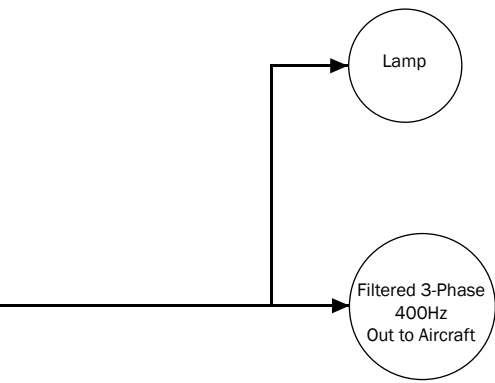

Figure 3.3.1 – Air intake and exhaust ports and internal air circulation



### 3.4 – Block Diagram





### 3.5 – Engine Starting Power

The user should always ensure that the unit has been charged to at least 80% of full charge (see Section 5.2 under Unit Charging) prior to ground support engine starting. However, in certain circumstances a full unit recharge may not be possible and immediate external engine starting power is required. The following chart provides minimum states of charge necessary to provide ample power for an efficient engine start under specific current load demands. Each LED on the Charge Status Meter indicates approximately 10% of charge.

% of Full Charge	40%	50%	60%	80%	100%
Charge Time (min)	5	7.5	9.25	11.5	12
Peak Current (amps)	< 1300	1300-1700	1700-2000	2400-3000	3000

Figure 3.5.1 – Engine starting power in amps versus percentage of battery charge

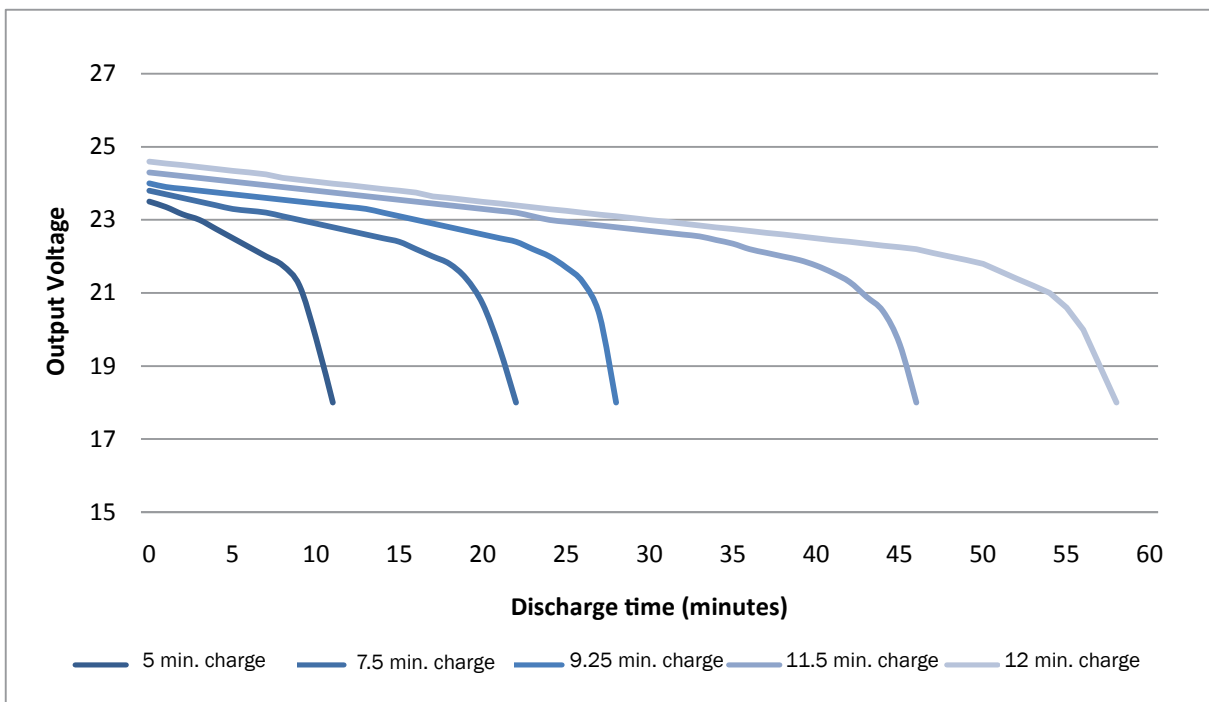



Figure 3.5.2 – Discharge time versus charge time

# Section 4 – Features Overview

## 4.1 – 3-Phase 60 Hz AC Input Cable Assembly and Cable Extension

 <b>CAUTION</b>	The hard-wired ac input cable can only be connected to 208-240 3-phase Vac 50/60 Hz 60 amp power. Connecting to any other type of ac power can cause damage to the GPU.
 <b>CAUTION</b>	Damage may occur if an unapproved or modified 3-phase ac cable extension or input plug is attached to the GPU.

The TI5400 400 Hz GPU-24 UAV ACDC is outfitted with a hard-wired 7-foot ac input cable with a 60 Hz 3-phase ac input plug (shown in Figure 4.1.1) and a 25-foot, 60 Hz 3-phase ac extension cable (see Figure 4.1.2). This cable is used to plug the GPU into 3-phase 208-240 Vac 50/60 Hz power. Only the Tesla™ ac cables and plugs provided should be used to plug the unit into ac power. When the plug is not in use, it can be secured by a Velcro® strap located at the back of the GPU (see Figure 4.1.3). To order a replacement ac input cable or plug, please contact the Tesla™ Customer Service at (302) 324-8910.



Figure 4.1.1 – Hard-wired AC Input cable and 3-phase 60Hz AC input plug



Figure 4.1.2– 3-phase AC cable extension (standard with unit).



Figure 4.1.3– AC plug Velcro strap

### 4.2 – 60 Hz 3-Phase AC Input Circuit Breaker

The 3-phase 60Hz AC Input Circuit Breaker is located at the center bottom of the GPU's front panel. (See Figures 4.2.1 and 4.2.2). It is also used as an On/Off Switch for powering the GPU.

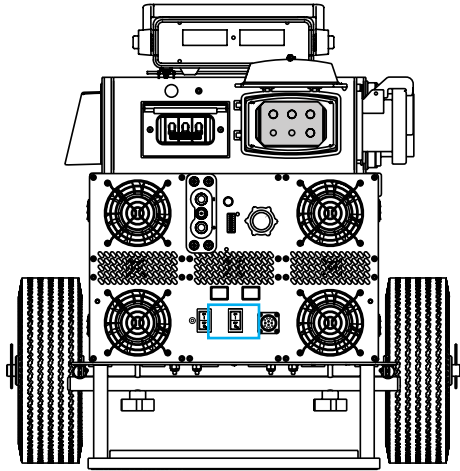

Figure 4.2.1 - Location of the 60Hz 3-Phase AC Input Circuit Breaker (outlined in blue)



Figure 4.2.2 - 3-phase 60 Hz Input Circuit Breaker

### 4.3 – Inverter Input Power Switch

The 60 Hz AC Inverter Power Switch, located at the bottom center of the TI5400 400Hz GPU-24 UAV ACDC's front panel (see Figures 4.3.1 and 4.3.2), connects the ac inverter directly to the internal cells, providing 120 Vac 60 Hz power. The LED next to the switch illuminates when the switch is on.

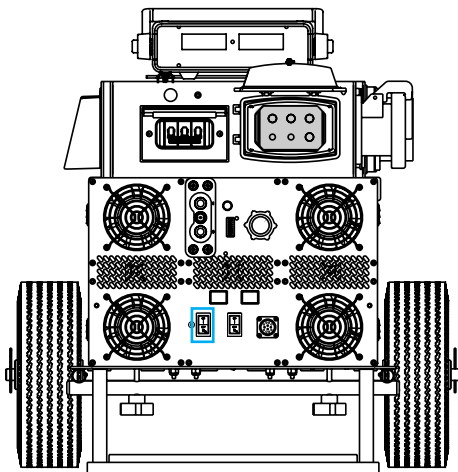

Figure 4.3.1 - Location of the 60Hz Inverter Power Switch (outlined in blue)



Figure 4.3.2 - 60 Hz Inverter Power Switch

#### 4.4 – DVAM Interface Receptacle

The DVAM (Digital Volt/Amp Meter) Interface Receptacle, located at the center bottom of the TI5400 400Hz GPU-24 UAV ACDC's front panel (see Figures 4.4.1 and 4.4.2), allows the user to measure the voltage and current at the DC Output Receptacle using the Tesla™ TI3100A DVAM (Digital Volt/ Amp Meter). Plug the TI3100A-0010 Power Cord into the Interface Receptacle and the back of the TI3100A DVAM to provide measurements for DC voltage.

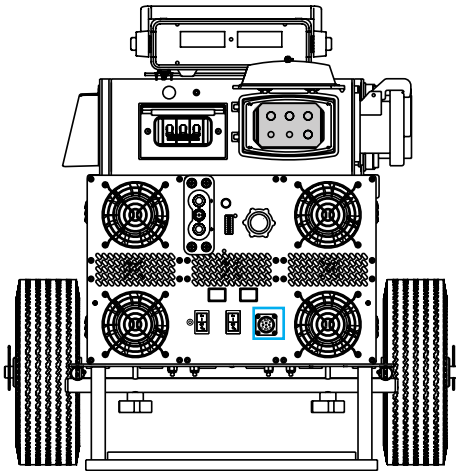

Figure 4.4.1 - Location of DVAM Interface Receptacle (outlined in blue)



Figure 4.4.2 - DVAM Interface Receptacle

#### 4.5 – Digital Volt / Amp Meter (TI3100A DVAM)

The Tesla™ Digital Volt / Amp Meter is a high powered measuring solution. The TI3100A DVAM provides measurements for DC voltage from 1 to 200 V and dc current up to 2000 amps for aircraft and vehicle. Integrated with the Tesla™ Turbo Start™ GPU power supply, DVAM is a valuable tool for troubleshooting and conducting systems checks.

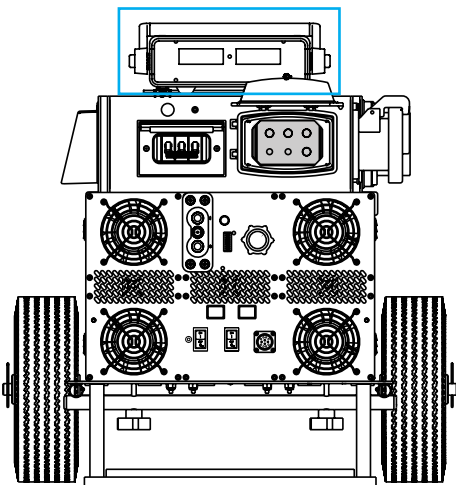

Figure 4.5.1 - Location of DVAM 3100A (outlined in blue)

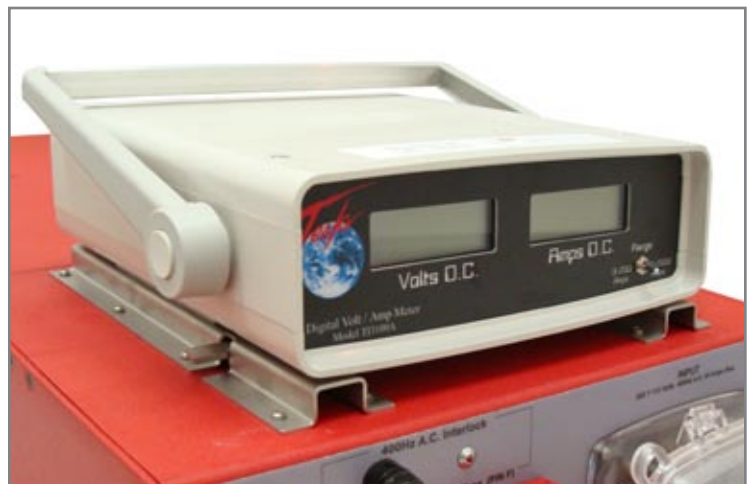

Figure 4.5.2 – TI3100A DVAM



### 4.6 – DC Output “ON” and “OFF” Buttons

The DC output “ON” and “OFF” buttons are located directly above the 60 Hz AC Input Circuit Breaker (see Figures 4.6.1 and 4.6.2 below). To prevent arcing while connecting or disconnecting dc power plugs, the TI5400 400Hz GPU-24 UAV ACDC has been equipped with an internal contactor. The “ON” button engages this contactor for safe transfer of power up to 3000 amps.

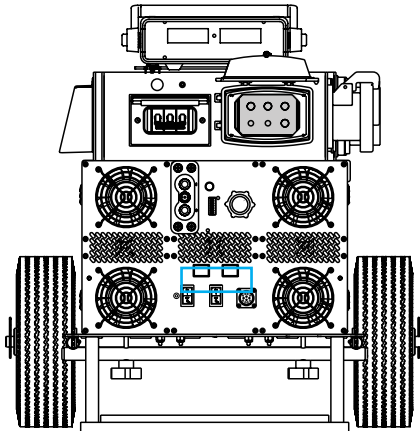

Figure 4.6.1 - Location of the DC Output On and Off Buttons (outlined in blue)



Figure 4.6.2 - DC Output “On” and “Off” Buttons

### 4.7 – DC Output Receptacle

The DC Output Receptacle (shown in Figures 4.7.1 and 4.7.2) will provide regulated 30.25 Vdc up to 400 amps when the unit is plugged into 3-phase power. Up to 3000 peak amps are available via the internal cells. Newer Units will be equipped with a protective cover. When the Output Connector is not in use, cover the receptacle with the protective cover. This will protect the Output Connector from dust and foreign matter.

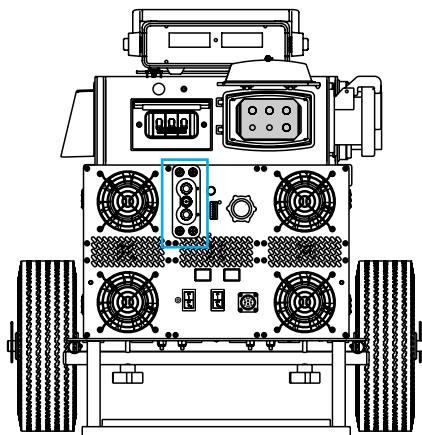



Figure 4.7.1 Location of the DC Output Receptacle (outlined in blue)



Figure 4.7.2 DC Output Receptacle

### 4.8 – “Push to Test” Button and LED Charge Status Meter

The “Push to Test” Button (see Figures 4.8.1 and 4.8.2) determines the load capacity of the power cells. This allows the user to determine if there is enough power to perform an engine start, or if the GPU needs to be recharged (see GPU Charging under Section 6.2).



**CAUTION**

Do not press the “Push to Test” button when either the ac or dc connections are made. Wait 2 minutes after disconnecting both plugs to ensure an accurate reading. Do not hold the “Push to Test” button for more than 5 seconds. This will trip a temperature sensor and disable the “Push to Test” function. If this occurs, allow 5 minutes for cooling before pushing the button again.

Figure 4.8.1 Location of the “Push to Test” and LED Status Meter (outlined in blue)

Figure 4.8.2 “Push to Test” and LED Status Meter

When attached to ac line voltage, the Charge Status Meter gives a visual indication of the power cells’ charge state (see Figure 4.8.3 below). Each LED indicates approximately 10% of charge. Additionally, the display will act as a load status indicator under high power demands (see Section 6.3 for more information).

<p><b>STATUS</b></p> <table border="1" style="border-collapse: collapse; width: 100%;"> <tr><td style="background-color: red; color: white;">R</td><td style="width: 10px;"></td><td style="background-color: red; color: white;">0</td></tr> <tr><td style="background-color: yellow;">Y</td><td style="width: 10px;"></td><td style="background-color: yellow;">1/2</td></tr> <tr><td style="background-color: green;">G</td><td style="width: 10px;"></td><td style="background-color: green;">OK</td></tr> <tr><td style="background-color: green;">G</td><td style="width: 10px;"></td><td style="background-color: green;">OK</td></tr> <tr><td style="background-color: green;">G</td><td style="width: 10px;"></td><td style="background-color: green;">OK</td></tr> <tr><td style="background-color: green;">G</td><td style="width: 10px;"></td><td style="background-color: green;">OK</td></tr> <tr><td style="background-color: green;">G</td><td style="width: 10px;"></td><td style="background-color: green;">OK</td></tr> <tr><td style="background-color: green;">G</td><td style="width: 10px;"></td><td style="background-color: green;">OK</td></tr> <tr><td style="background-color: green;">G</td><td style="width: 10px;"></td><td style="background-color: green;">OK</td></tr> <tr><td style="background-color: green;">G</td><td style="width: 10px;"></td><td style="background-color: green;">OK</td></tr> </table> <p>Full Charge</p>	R		0	Y		1/2	G		OK	G		OK	G		OK	G		OK	G		OK	G		OK	G		OK	G		OK	<p><b>STATUS</b></p> <table border="1" style="border-collapse: collapse; width: 100%;"> <tr><td style="background-color: red; color: white;">R</td><td style="width: 10px;"></td><td style="background-color: red; color: white;">0</td></tr> <tr><td style="background-color: yellow;">Y</td><td style="width: 10px;"></td><td style="background-color: yellow;">1/2</td></tr> <tr><td style="background-color: green;">G</td><td style="width: 10px;"></td><td style="background-color: green;">OK</td></tr> <tr><td style="background-color: green;">G</td><td style="width: 10px;"></td><td style="background-color: green;">OK</td></tr> <tr><td style="background-color: green;">G</td><td style="width: 10px;"></td><td style="background-color: green;">OK</td></tr> <tr><td style="background-color: green;">G</td><td style="width: 10px;"></td><td style="background-color: green;">OK</td></tr> <tr><td style="background-color: green;">G</td><td style="width: 10px;"></td><td style="background-color: green;">OK</td></tr> <tr><td style="background-color: green;">G</td><td style="width: 10px;"></td><td style="background-color: green;">OK</td></tr> <tr><td style="background-color: green;">G</td><td style="width: 10px;"></td><td style="background-color: green;">OK</td></tr> <tr><td style="background-color: green;">G</td><td style="width: 10px;"></td><td style="background-color: green;">OK</td></tr> </table> <p>Half Charge</p>	R		0	Y		1/2	G		OK	G		OK	G		OK	G		OK	G		OK	G		OK	G		OK	G		OK	<p><b>STATUS</b></p> <table border="1" style="border-collapse: collapse; width: 100%;"> <tr><td style="background-color: red; color: white;">R</td><td style="width: 10px;"></td><td style="background-color: red; color: white;">0</td></tr> <tr><td style="background-color: yellow;">Y</td><td style="width: 10px;"></td><td style="background-color: yellow;">1/2</td></tr> <tr><td style="background-color: green;">G</td><td style="width: 10px;"></td><td style="background-color: green;">OK</td></tr> <tr><td style="background-color: green;">G</td><td style="width: 10px;"></td><td style="background-color: green;">OK</td></tr> <tr><td style="background-color: green;">G</td><td style="width: 10px;"></td><td style="background-color: green;">OK</td></tr> <tr><td style="background-color: green;">G</td><td style="width: 10px;"></td><td style="background-color: green;">OK</td></tr> <tr><td style="background-color: green;">G</td><td style="width: 10px;"></td><td style="background-color: green;">OK</td></tr> <tr><td style="background-color: green;">G</td><td style="width: 10px;"></td><td style="background-color: green;">OK</td></tr> <tr><td style="background-color: green;">G</td><td style="width: 10px;"></td><td style="background-color: green;">OK</td></tr> <tr><td style="background-color: green;">G</td><td style="width: 10px;"></td><td style="background-color: green;">OK</td></tr> </table> <p>No Charge</p>	R		0	Y		1/2	G		OK	G		OK	G		OK	G		OK	G		OK	G		OK	G		OK	G		OK
R		0																																																																																										
Y		1/2																																																																																										
G		OK																																																																																										
G		OK																																																																																										
G		OK																																																																																										
G		OK																																																																																										
G		OK																																																																																										
G		OK																																																																																										
G		OK																																																																																										
G		OK																																																																																										
R		0																																																																																										
Y		1/2																																																																																										
G		OK																																																																																										
G		OK																																																																																										
G		OK																																																																																										
G		OK																																																																																										
G		OK																																																																																										
G		OK																																																																																										
G		OK																																																																																										
G		OK																																																																																										
R		0																																																																																										
Y		1/2																																																																																										
G		OK																																																																																										
G		OK																																																																																										
G		OK																																																																																										
G		OK																																																																																										
G		OK																																																																																										
G		OK																																																																																										
G		OK																																																																																										
G		OK																																																																																										

Figure 4.8.3 LED Status Meter charge state

T15400 400Hz GPU-24 UAV ACDC

17

## 4.9 – 400 Hz AC Input

**CAUTION**

The 200 Y 115 3-phase Vac 400 Hz input can only be connected to a 3-phase 400 Hz 200 Y 115 Vac power source. Any other type of ac power may cause damage to the GPU.

**CAUTION**

Damage may occur if an unapproved or modified ac line cable or input plug is attached to the GPU. Do not use any type of ac voltage converter.

The TI5400 400Hz GPU-24 UAV ACDC comes equipped with a 3-phase 400 Hz 200 Y 115 Vac Input located above the front faceplate under a transparent weatherproof cover. (see Figures 4.9.1 and 4.9.2). This input receives a 400 Hz cable assembly that comes standard with the GPU and will connect to any 3-phase 400 Hz 200 Y 115 Vac receptacle.

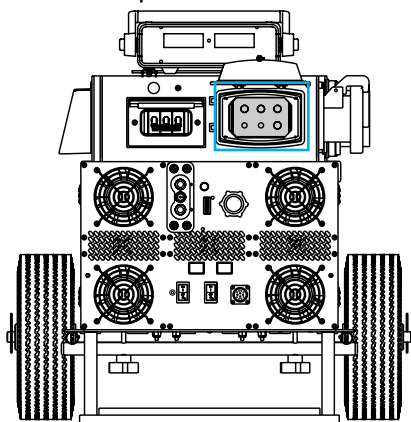

Figure 4.9.1 Location of the 400Hz AC Input (outlined in blue)



Figure 4.9.2 3-phase 400 Hz AC Input

## 4.10 – 400 Hz AC Input Circuit Breaker

The 400 Hz AC Input Circuit Breaker, located on the top left of the GPU's front panel underneath a weatherproof cover (see Figure 4.10.1), serves as the "On/Off" Switch for the 400 Hz AC Input. When activated, it provides power to the GPU, but does not have any effect on the 400 Hz 200 Y 115 Vac Output. To disconnect power from the 400 Hz AC Output, refer to Section 4.15 under 400 Hz AC Output Circuit Breaker.

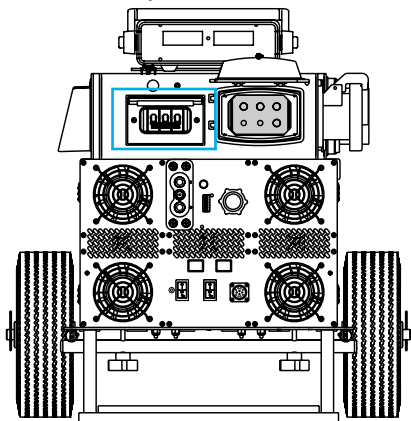

Figure 4.10.1 - Location of the 400 Hz AC Input Circuit Breaker (outlined in blue)



Figure 4.10.2 - 400 Hz AC Input Circuit Breaker

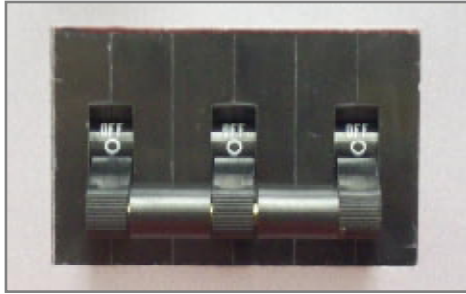

Figure 4.10.3 - Breaker Set to OFF position.

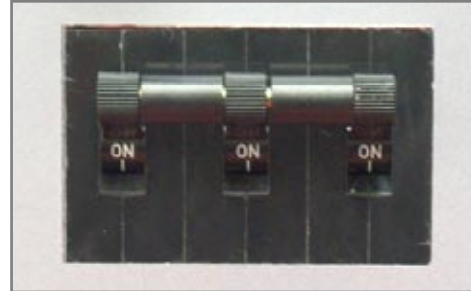

Figure 4.10.4 - Breaker Set to ON position.

#### 4.11 – 400Hz Input Interlock Lamp

The 400 Hz Input Interlock LED, located on the top left of the GPU's front panel above the 400 Hz Input Circuit Breaker (see Figures 4.11.1 and 4.11.2), illuminates when the 400 Hz AC Input Circuit Breaker is set to the "ON" position.

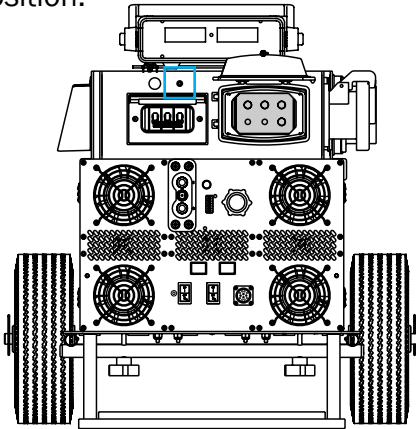

Figure 4.11.1 - Location of 400Hz Input Interlock Lamp (outlined in blue)



Figure 4.11.2 - 400Hz Input Interlock Lamp

#### 4.12 – 400Hz Interlock Breaker

The 400 Hz Interlock Breaker, located on the top left of the GPU's front panel above the 400 Hz Input Circuit Breaker (see Figures 4.12.1 and 4.12.2), protects the internal interlock circuitry from potential shorts in the 400 Hz cable or external equipment.

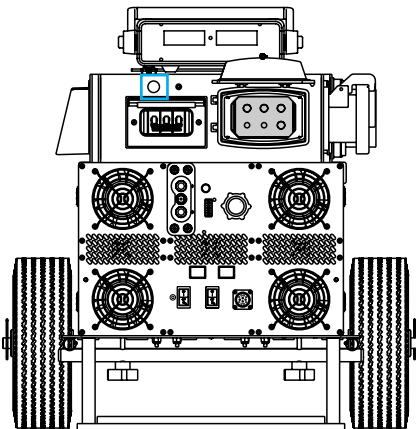

Figure 4.12.1 - Location of the 400Hz Interlock Breaker (outlined in blue)



Figure 4.12.2 - 400Hz Interlock Breaker

### 4.13 – 400 Hz Surge/EMC Filter

The 400 Hz Surge/EMC Filter, located on the top center of the GPU’s side panel (see Figures 4.13.1 and 4.13.2), provides filtering for the 400 Hz Vac Output. Connected directly to the 400 Hz AC Input, the filter eliminates potentially harmful surges and high frequency noise and harmonics.

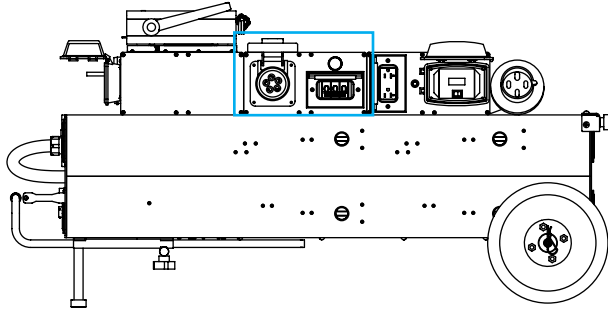

Figure 4.13.1 - Location of the 400Hz Surge/EMC Filter (outlined in blue)



Figure 4.13.2 - 400Hz Surge/EMC Filter

### 4.14 – 400 Hz 200 Y 115 Vac Output

	NOTE	The 400 Hz AC Input must be connected to a power source to use the Output.
--	------	--

The 400 Hz 200 Y 115 Vac Output, located on the top left of the GPU’s side panel (see Figures 4.14.1 and 4.14.2), provides filtered 400 Hz 200 Y 115 Vac at 30 amps. Connected directly to the 400 Hz AC Input through a filtering circuit, the output is not affected by the state of the 400 Hz AC Input Circuit Breaker. Only the 400 Hz AC Output Circuit Breaker controls this output.

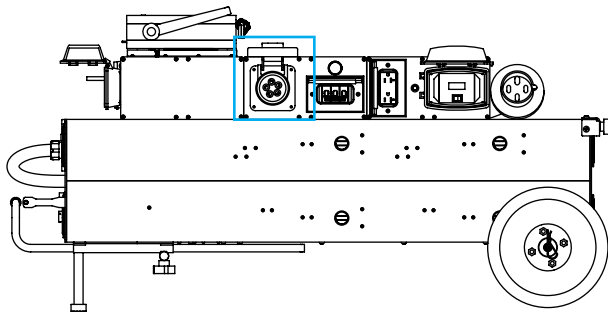

Figure 4.14.1 Location of the 400Hz 200 Y 115 Vac Output (outlined in blue)



Figure 4.14.2 400Hz 200 Y 115 Output



#### 4.15 – 400 Hz AC Output Circuit Breaker and Power Indicator

The 400 Hz AC Output Circuit Breaker, located on the top center of the GPU's side panel underneath a weatherproof cover (see Figures 4.15.1 and 4.15.2), serves as an “On/Off” Switch for the 400 Hz AC Output. When activated it provides power to the 400 Hz 200 Y 115 Vac Output up to 30 amps. The Power Indicator will illuminate when 400 Hz power is present and the AC Output Circuit Breaker is set to “ON.”

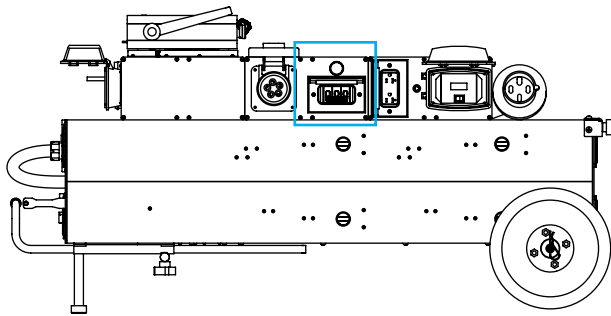

Figure 4.15.1 - Location of the 400Hz Output Circuit Breaker and Power Indicator (outlined in blue)

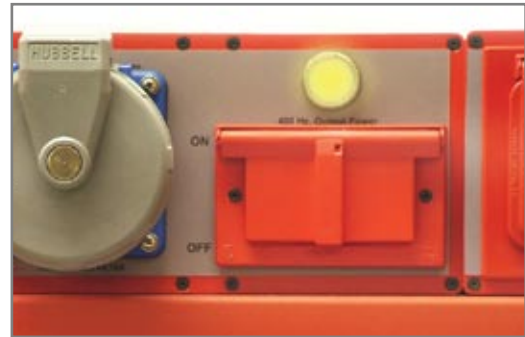

Figure 4.15.2 - 400Hz Output Circuit Breaker and Power Indicator

#### 4.16 – Inverter Display Panel

The Inverter Display Panel, located on the top right of the GPU's side panel underneath a weatherproof cover (see Figure 4.16.1), provides information about the dc input voltage and current levels as well as the amount of ac power going out (see Figure 4.16.2). If either the 60 Hz AC Inverter Power Switch or the Inverter On/Off Switch are switched “OFF” the Inverter Display Panel LCD will turn off, indicating that the inverter is “OFF.”

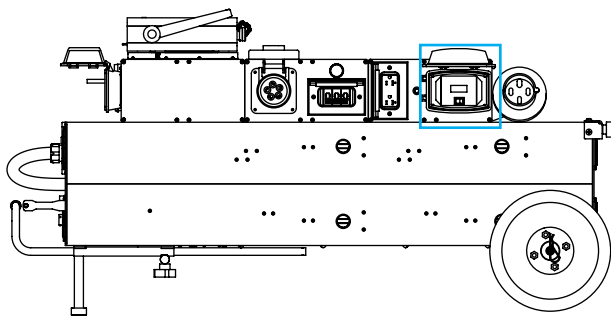

Figure 4.16.1 Location of the Inverter Display Panel (outlined in blue)



Figure 4.16.2 Inverter Display Panel



### 4.17 – Inverter On/Off Switch

The Inverter On/Off Switch, located on the top right of the GPU’s side panel below the Inverter Display Panel (see Figures 4.17.1 and 4.17.2), activates the internal circuitry of the Pure Sine Wave Inverter. When switched to the “ON” position the LCD display will illuminate and the Power Outlet will provide 120 Vac at 15 amps continuous (1800 watts).

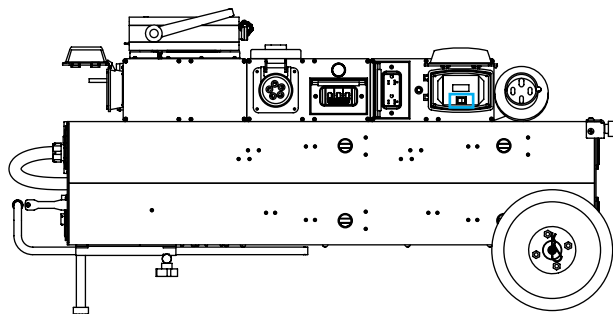

Figure 4.17.1 - Location of the Inverter On/Off Switch (outlined in blue)



Figure 4.17.2 - Inverter On/Off Switch

### 4.18 – 60 Hz 120 Vac Power Outlet and Circuit Breaker

The 60Hz 120 Vac Power Outlet and Circuit Breaker are located on the top right of the GPU’s side panel next to the Inverter Display Panel (see figures 4.18.1 and 4.18.2). When the Inverter is active the Power Outlet will provide 120 Vac at 16.66 A continuous and up to 20 A peak for the 2 kW unit. If the load exceeds 20 A, the Inverter Output Circuit Breaker will trip.

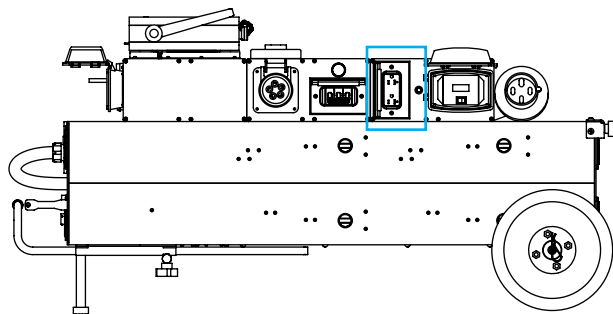

Figure 4.18.1 - Location of the 60Hz 120 Vac Output and Circuit Breaker (outlined in blue)



Figure 4.18.2 - 60Hz 120 Vac Output and Circuit Breaker

## 4.19 – Telescopic Handle

The Telescopic Handle, located on the bottom front of the GPU (see figures 4.19.1 and 4.19.2), makes maneuvering the TI5400 400Hz GPU-24 UAV ACDC easy and a rubber grip allows the user to firmly grip the handle. When the unit has been positioned, the handle can be retracted to reduce the unit footprint.

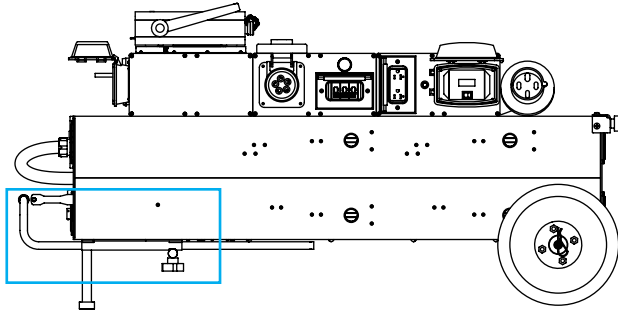

Figure 4.19.1 - Location of the Telescopic Handle (outlined in blue)



Figure 4.19.2 - Retractable Telescopic Handle

## 4.20 – Run-Flat Removable Tires

The Run-Flat Removable Tires, located on the bottom rear of the TI5400 400Hz GPU-24 UAV ACDC (see figure 4.20.1 and 4.20.2), make it easy to move the GPU. When the unit has been positioned, the tires can be quickly detached by removing the two cotter pins, making it easy for replacement. The tires feature sealed bearings in the wheel hub to keep out dust and moisture.

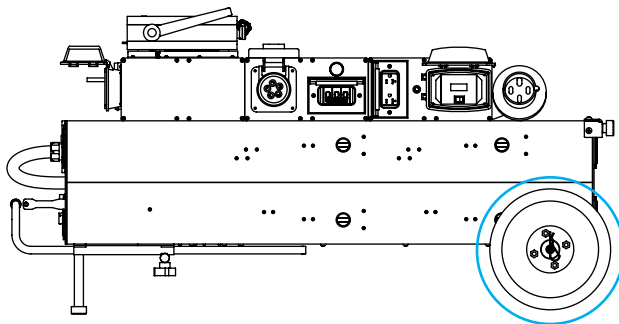

Figure 4.20.1 - Location of the Removable Tires (outlined in blue)



Figure 4.20.2 - Removable Tires

## 4.21 – Air Exhaust Fans

 **CAUTION**

Damage may occur if the TI5400 400Hz GPU-24 UAV ACDC's air intake or outlet ports are obstructed. Ensure that all ports are clear at all times.

There are four intake fans on the front and five cooling exhaust fans mounted on the back of the TI5400 400Hz GPU-24 UAV ACDC (see figure 4.21.1 and 4.21.2). The internal cooling system of the TI5400 400Hz GPU-24 UAV ACDC has been designed to efficiently regulate unit temperature regardless of load (see figure 4.21.3). See Section 3.3 for more information.

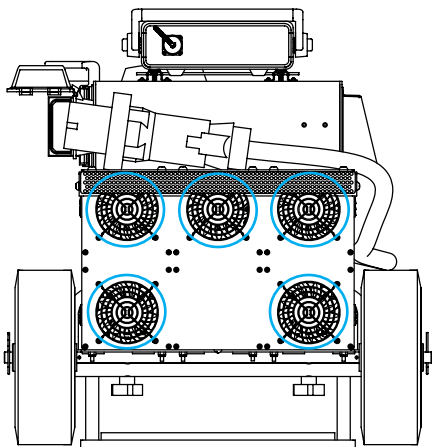

Figure 4.21.1 - Location of the Air Exhaust Fans (outlined in blue)



Figure 4.21.2 - Air Exhaust Fans

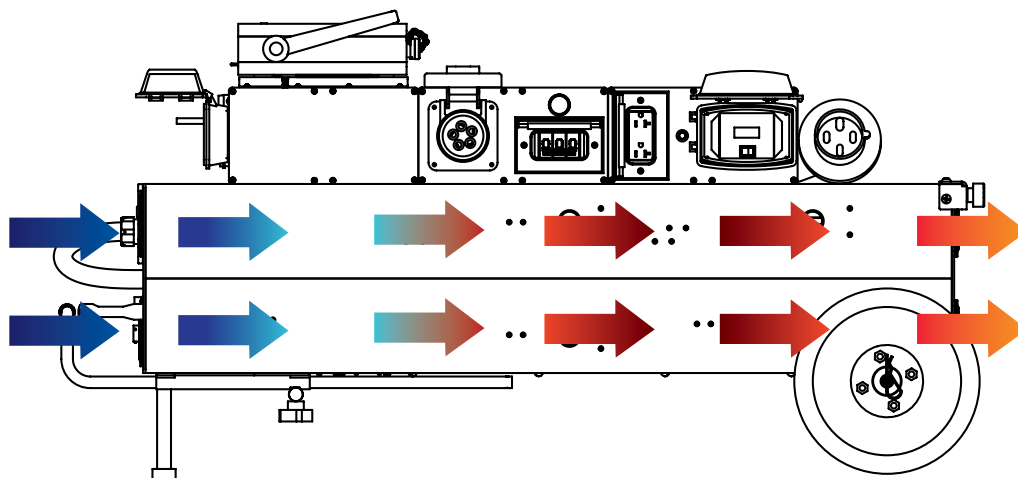

Figure 4.21.3 - Air intake and exhaust ports and internal air circulation.

# Section 5 – Pre-Operation Procedures

## 5.1 – Temperature Specifications

### Cold/Hot Soaked Temperature

Exposing the unit for one (1) hour or more to the ambient temperature establishes the unit’s cold/hot soaked stabilization temperature. If the unit’s cold/hot soaked temperature is outside the normal operating temperature range, the unit must be stabilized prior to operation. For COLD SOAKED temperature stabilization, the unit must be placed in an environment with a temperature above +10°C (+41°F) for 3 hours or a temperature above +20°C (+68°F) for 2 hours. For HOT SOAKED temperature stabilization, the unit must be placed in an environment with a temperature below +38°C (+100°F) for 1 hour.

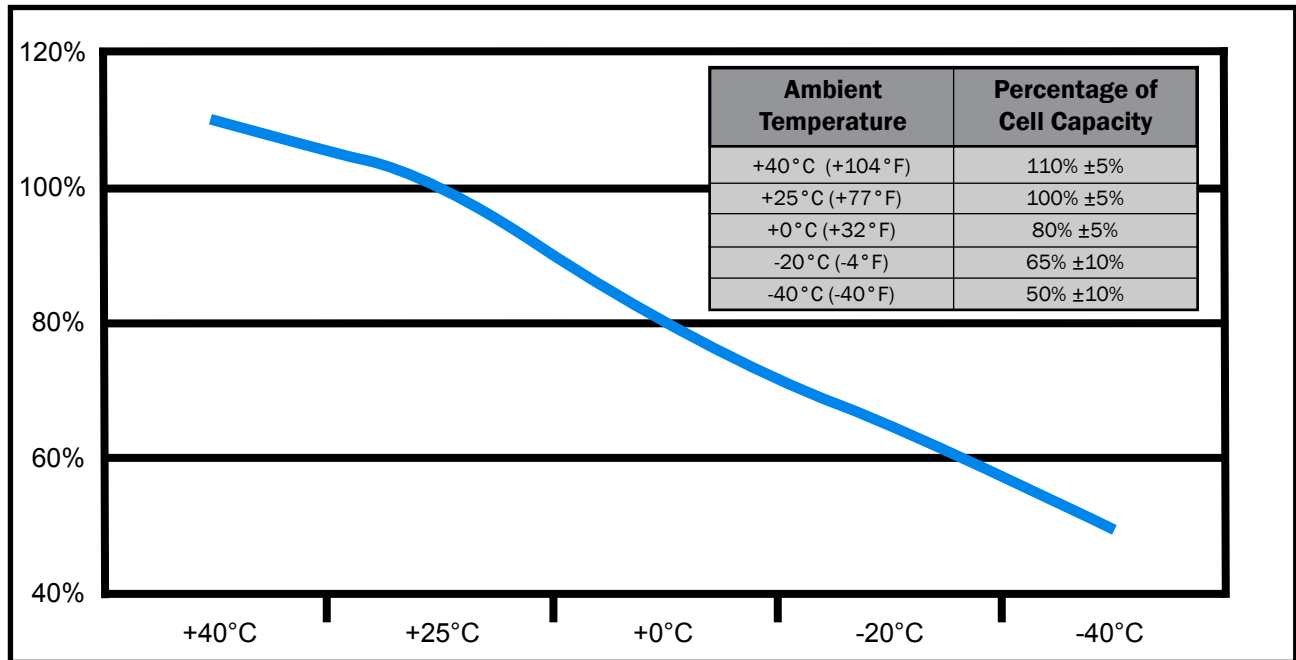

Figure 5.1.1 – Cell storage capacity versus ambient temperature

### Hot Soaked or Cold Soaked Definition

Simple terms: When a material is exposed to a change in temperature, its temperature will also change. Some material changes temperature quickly, others slowly. If the ambient temperature changes and is then held constant, the materials temperature will also change until its temperature stabilizes. Once the material temperature has stabilized, it is considered “soaked”.

Example: A unit is moved from the cool shade into the hot sun. That unit’s temperature will increase until it stabilizes. Once stabilized, the unit would be considered “hot soaked”.



#### NOTE

The unit’s temperature switch automatically disables ac power functions when the internal temperature is above 150°F (65°C). This protects the unit from overheating and damage. If the unit shuts down, move the unit into a cooler climate, such as shade or air conditioning when possible. Perform a full function test prior to use after the unit has been allowed to cool.

	<b>NOTE</b>	Plug the TI5400A 400Hz GPU-24 UAV ACDC into ac power to keep the cells charged whenever it is not in use, even if it is at Full Charge. The unit will not overcharge or overheat.
---	-------------	---

## 5.2 – Unit Charging

### Attaching AC Input Power

Before operating the TI5400 400Hz GPU-24 UAV ACDC, it is recommended to fully charge the unit. The GPU can be plugged into either a 50/60 Hz 3-phase 208-240 Vac outlet (see figures 5.2.1) or a 400Hz 3-phase 200 Y 115 Vac outlet (see figure 5.2.2).

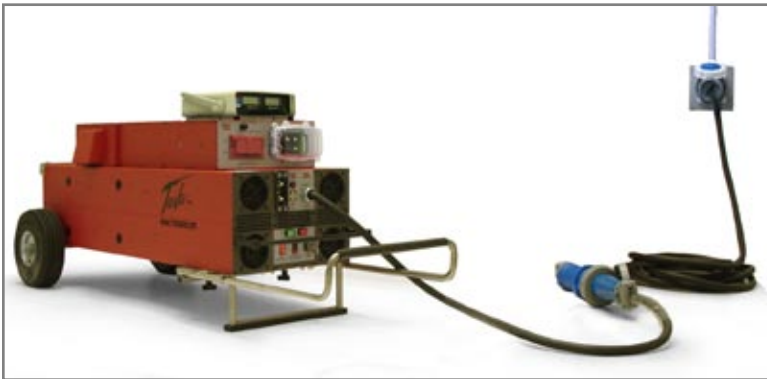

Figure 5.2.1 – Hard-wired AC Input cable and 3-phase 60Hz AC input plug

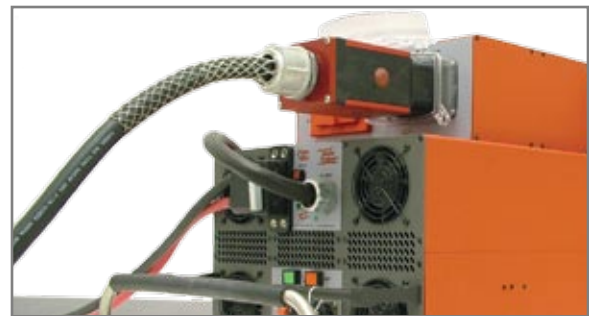

Figure 5.2.2 – 400Hz 3-Phase 200 Y 115 Vac

### Turning on AC Power

If the 3-Phase 60Hz AC Input is used, the 60Hz 3-Phase AC Input Circuit Breaker must be set to the “ON” position (see figure 5.2.3). Otherwise, if the 400Hz AC Input is used, the 400Hz AC Input Circuit Breaker must be set to the “ON” position (see figure 5.2.4).



Figure 5.2.3 - 60Hz AC Input Circuit Breaker set to the “ON” position.



Figure 5.2.4 - 400Hz AC Input Circuit Breaker set to the “ON” position.

## Charging the Power Cells

The Charge Status Meter will immediately show the current charge state of the power cells. Make sure there are at least 2 to 3 inches of clearance in front of the Air Exhaust Fans to provide for sufficient ventilation. If the GPU is completely discharged, a minimum of 12 minutes will be required to fully charge the GPU.

## LED and Fan Activity

Initially, several LEDs will be illuminated on the Status Meter (see left image in figure 5.2.5). As the unit charges, the LEDs will go out one by one. Under a full charge, the Meter will show a single solid green LED. In addition, the fan will be running at reduced RPM. This indicates that the unit is in standby mode and ready for use.

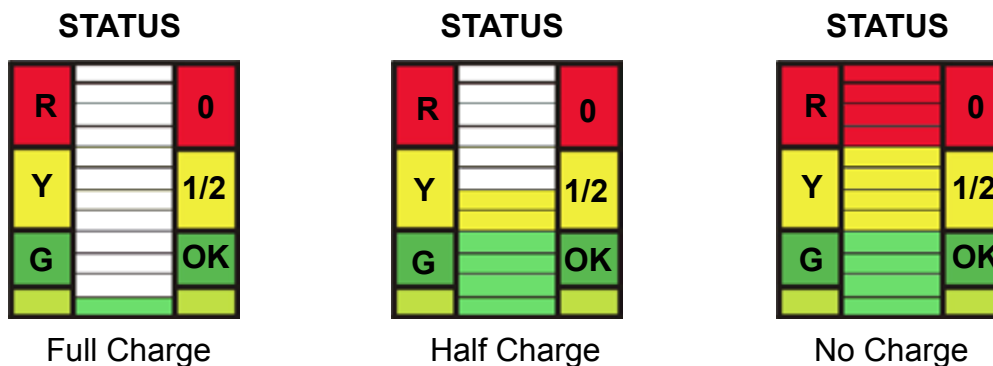

Figure 5.2.5 - Charge Status Meter

## 5.3 – Maintenance Check

Check the GPU for dents, punctures, case distortion or misalignment, and cracked or loose connectors. Check cables for cuts, chafing or evidence of crushing. Check connectors for cracks, cuts, distortion, excessive wear, broken/loose fasteners, and cables or strain reliefs. Also be sure to check the tires. The GPU comes equipped with solid run-flat tires. No air is required, but if the tires are damaged they can easily be replaced. If no external damage is evident, proceed to the next step, otherwise, contact Tesla™ for further instructions.

## 5.4 – Checking Cell Capacity

To check the Cell Capacity, set the appropriate AC Input Circuit Breaker to the “OFF” position and wait for approximately two minutes. Then, press the “Push to Test” button to verify that the power cells are fully charged. Under a full charge the Charge Status Meter will show a single green LED (as shown in figure 5.2.5) and one fan will activate. The unit is now ready for normal operation.



### NOTE

If the unit is not fully charged after 30 minutes, the power cells may need to be replaced. Return the unit to Tesla™ for evaluation and maintenance.





# Section 6 – Operating Procedures

## 6.1 – Operating Overview

The TI5400 400Hz GPU-24 UAV ACDC has three primary functions that will be discussed in this section. 1) Providing 30.25 Vdc continuous regulated output power, 2) powering aircraft systems, and 3) power conversion via a convenient 120 Vac power outlet. Step-by-step instructions will be given for performing each function.

## 6.2 – Regulated 30.25 Vdc Output Power

 <b>WARNING</b>	Make sure that the unit is at least 20 feet (6 meters) away from the nearest fueling source before connecting the dc plug.
--	--

 <b>WARNING</b>	Severe injury or death from electrical shock will occur if either the user or the TI5400 400Hz GPU-24 UAV ACDC is wet while operating the unit with the 120-240 Vac power source attached. Be sure to disconnect ac power from the ac source if the TI5400 400Hz GPU-24 UAV ACDC has come into contact with water. If either AC Input Circuit Breaker has tripped, due to water infiltration, DO NOT try to reset it with the ac line voltage attached.
--	---

The 400 Hz AC Input Circuit Breaker, located on the top box of the GPU’s front panel underneath a weatherproof cover (see Figure 4.10.1), serves as the “On/Off” Switch for the 400 Hz AC Input. When activated it provides power to the GPU, but does not have any effect on the 400 Hz 200 Y 115 Vac Output Filter. To disconnect power from the 400 Hz AC Output, refer to Section 4.15 under 400 Hz AC Output Circuit Breaker.

### Checking Unit Charge State

Press the “Push to Test” button and check the Charge Status Meter (see figure 6.2.1). Only the green OK section of the Charge Status Meter should be lit (see figure 6.2.2), signifying a minimum of 80% of full charge. If the yellow or red sections of the charge status meter are lit, the unit will not provide the maximum rated output current. Each LED indicates approximately 10% of charge. See Section 3.5 for further information regarding minimum charge times versus output current capability.



Figure 6.2.1 “Push to Test” and Status Meter

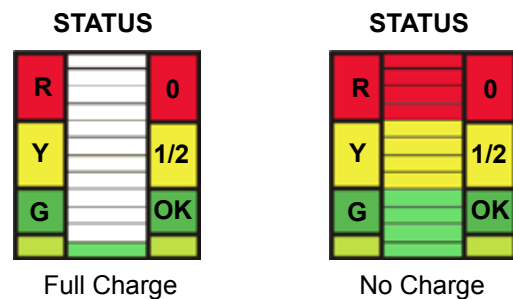



Figure 6.2.2 Charge Status Meter

 <b>NOTE</b>	Do not press the “Push to Test” button when either the ac or dc connections are made. Wait 2 minutes after disconnecting both plugs to ensure an accurate reading. Do not hold the “Push to Test” button for more than 5 seconds. This will trip a temperature sensor and disable the “Push to Test” function. If this occurs, allow 5 minutes for cooling before pushing the button again.
---	---

## Disabling DC Output Receptacle

To prevent potential arcing and connector damage, press the DC Output “OFF” button to ensure that the DC Output Receptacle is disabled. The “ON” button should not be illuminated. (see figures 6.2.3 and 6.2.4)

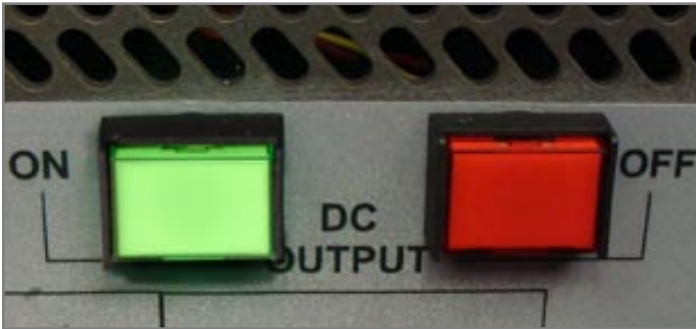

Figure 6.2.3 DC Output “OFF”

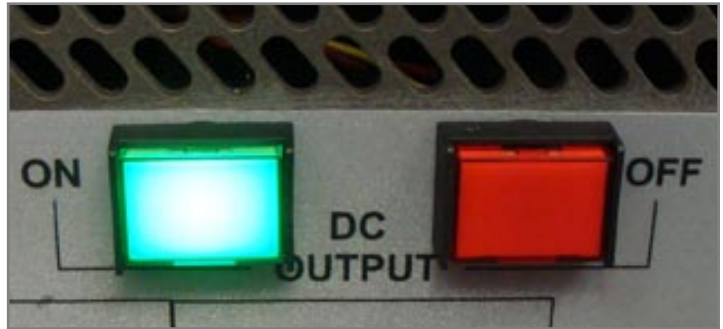

Figure 6.2.4 DC Output “ON”  
and Switch is Illuminated

## Attaching DC Plug Cable Assembly

Attach the DC Output Connector to the DC Output Receptacle by pushing the connector into place and turning the T-handle on the connector clockwise until it locks. (See figure 6.2.5)

Next, attach the DC Aviation Plug to the aircraft, making sure that it is properly seated in the DC Receptacle. Consult the aircraft’s operator manual for receptacle location.

The T15400 400Hz GPU-24 UAV ACDC is now ready to safely transfer up to 3000 amps. When ready, press the unit’s DC Output “ON” button. The button should illuminate green (see figure 6.2.4). DC power should be on and the aircraft’s voltmeter should read between 23 and 26 Vdc (without ac power).

To transfer power internally to the aircraft, the user should follow system operating procedures as specified in the aircraft’s operator manual.

When power is no longer needed, make sure to press the DC Output “OFF” button before disconnecting any plugs (see figure 6.2.3). Once confirming that the DC Output is “OFF”, the user can safely proceed to disconnect the cable.



Figure 6.2.5 Connect DC cable to GPU



### 6.3 – 400Hz 200 Y 115 3-Phase 30 AMP Vac Disabling the 400Hz AC Input and 400 Hz AC Output

To prevent potential arcing or connector damage, place the 400Hz 3-Phase Vac AC INPUT circuit breaker to the “OFF” position (figure 6.3.2) before connecting either end of the 400 Hz aircraft power cable.

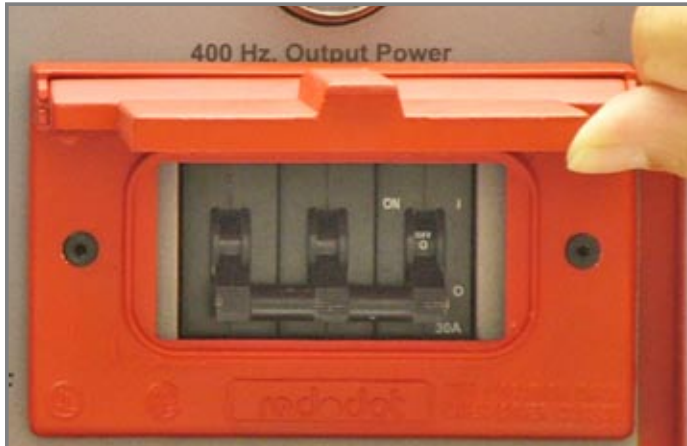

Figure 6.3.1 - 400Hz AC Input Circuit Breaker set to the “ON” position.



Figure 6.3.2 - 400Hz AC Input Circuit Breaker set to the “OFF” position.

### Attaching 400Hz AC Input Cable and 400Hz Aircraft Power Cable

Attach the 400Hz power cable from any compatible power source to the 400Hz AC Input Receptacle by lifting the protective cover and pushing the connector firmly into place (see figure 6.3.3). Next, connect the 400Hz Aircraft Plug from the aircraft to the 400Hz ac power source, making sure that it is fully seated into the ac receptacle (see figure 6.3.4).



Figure 6.3.3 Connecting 400Hz power cable to 400Hz AC Input Receptacle

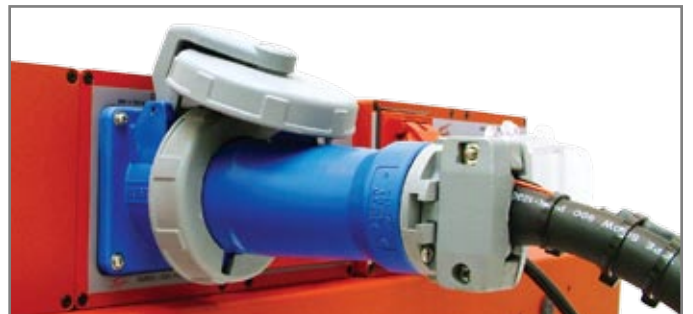

Figure 6.3.4 Connecting 400Hz power cable to Aircraft

## Attaching 400Hz AC Output Cable

Attach the aircraft's ac input power cable to the 400Hz 200 Y 115 Vac Output Receptacle ( figure 6.3.5) by turning the circular cover counterclockwise and lifting it up. Insert the ac input plug and push firmly into place. Then lock the connector collar. The cover will stay open once plug is in place.

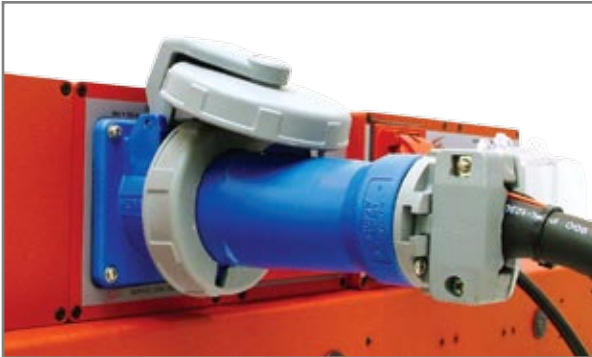

Figure 6.3.5 400Hz AC Output Power Cable connected

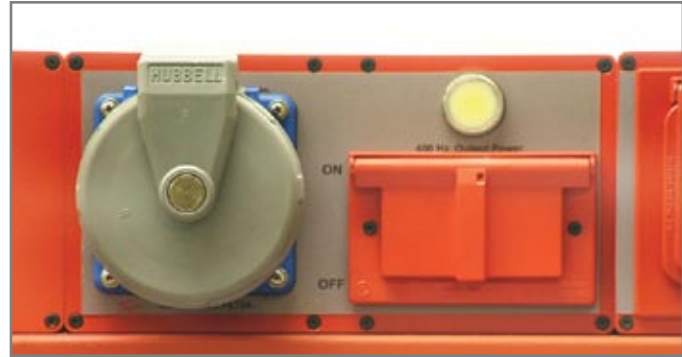

Figure 6.3.6 400Hz Output Power Indicator

Connect the AC Output power cable to the aircraft, making sure that it is fully seated into the ac receptacle. Turn the 400Hz AC Input Circuit Breaker (see Figure 6.3.1) to the “ON” position. The unit is now ready to safely transfer power and will provide a clean source of 400Hz power via the 400Hz Surge/EMC Filter.



### NOTE

Regardless of whether the 400 Hz input is being used to power the GPU, the 400 Hz power is routed to the 400 Hz AC Filter Input to take advantage of the TI5400 400Hz GPU-24 UAV ACDC's advanced filtering technology.

## Activating/Deactivating the 400Hz AC Output

When ready, set the 400Hz Output Circuit Breaker to the “ON” position. The 400Hz Output Power Indicator Lamp should illuminate as illustrated in figure 6.3.6.



### NOTE

If the user only needs 400Hz power out through the filter, it is not necessary to activate the 400Hz Input Circuit Breaker. The Filter works independently of the Main input Circuit Breaker. Setting this breaker to the “ON” position will provide power to the GPU, but it does not affect the transfer of power to the 400Hz AC Output Receptacle.

## Disconnecting the 400Hz AC Input and Output

When power is no longer needed, make sure to set the 400Hz Input and Output Circuit Breakers to the “OFF” position before disconnecting any plugs (refer to figures 6.3.1 and 6.3.2). The 400Hz AC Output Power Indicator should turn off. After confirming that the 400Hz AC Output is “OFF”, the user can safely proceed to disconnect the cables.

## 6.4 – 60Hz 120 Vac Power Outlet

### Enabling the 60Hz 120 Vac Power Outlet

To activate the 60Hz 120 Vac Power Outlet, first set the 60Hz AC Inverter Power Switch to the “ON” position (see figure 6.4.1). This provides power directly from the internal cells to the Pure Sine Wave Inverter. If the batteries are charged, the LED next to the 60Hz AC Inverter Power Switch LED will illuminate as shown in figure 6.4.1.

Next, set the Inverter On/Off switch to the “I” position. Initially, the screen on the LCD Display will indicate the input voltage, output voltage and frequency configuration. Then the screen will display input voltage, input current and output power (see figure 6.4.2). The 60Hz 120 Vac Power Outlet is now active.



Figure 6.4.1 60Hz AC Inverter Power Switch “ON”



Figure 6.4.2 Inverter Display Panel with Switch set to “I” (ON) position.

### Control Panel and LCD Display

The Pure Sine Wave Inverter is equipped with a Control Panel that displays operational information so you can monitor the status of the inverter and the GPU’s power cells. A backlit LCD display shows both input voltage and current from the power cells. Actual output power (in watts) from the inverter will be displayed when equipment is plugged into the power outlet. In figure 6.4.2 the inverter has an input voltage of 24.4V with a current draw of 27A. The resulting output power is displayed on an analog bar and reads 400W.



#### NOTE

When activated, the power outlet will operate with or without ac power attached.

## Operating the Pure Sine Wave Inverter

Once the standard display screen is shown, any type of 120 Vac load can be attached to the 60Hz 120 Volt AC Outlet (see figure 6.4.4), including cell phone chargers, laptops and any other electronic devices. When equipment is plugged in, the output power is displayed in watts on an analog bar graph at the bottom of the LCD display.

### Inverter Fan

When the Inverter is initially powered on, it is normal for the fan to be off. Once an ac load is applied to the Inverter, the fan will turn on. The fan will continue to run until the ac load is disconnected. Once the ac load is disconnected the fan will decrease in RPM and eventually turn off (depending on how hot the temperature of the Inverter is) to conserve power.



Figure 6.4.3 Inverter Fan

### Sine Wave Powersave Mode

The Sine Wave Inverter has a built-in “Powersave” mode to reduce the drain on the power cells when no load is present. This mode (when enabled) checks the output for a load every 2.5 seconds and will automatically power up with a load of at least 10 watts. To enable/disable this feature, set the Inverter Power Switch to “O” and then “I”. When the “PWR SAVE” screen comes up, quickly set the power switch to “O”, wait three seconds, and set the switch to “I”. This will toggle the “Powersave” function on and off.

### GFCI Outlet Test and Reset Buttons

The inverter output is equipped with a GFCI outlet that will protect the user from potentially dangerous shocks due to faulty grounding (see figure 6.4.4). Pressing the “Test” button will trip the outlet and break the circuit. Pressing “Reset” will restore the circuit assuming no ground fault is present. The green LED will illuminate when the receptacle is live. In the event that the outlet does not work after resetting both the Inverter Output Circuit Breaker (see figure 6.4.5) and the GFCI receptacle, contact Tesla™ for further instructions.



Figure 6.4.4 60Hz 120 Volt AC Outlet with GFCI receptacle.

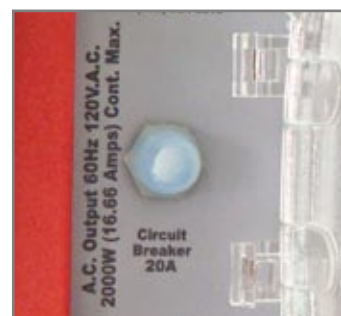

Figure 6.4.5 Inverter Output Circuit Breaker for 60Hz 120 Vac Output.

## Inverter Output Circuit Breaker

The AC Input Circuit Breaker is located to the left of the AC Inverter Display. When the circuit breaker has been tripped, the button will pop out. In the event the breaker trips:

1. Disconnect any ac plugs.
2. Wait for a minimum of 60 seconds.
3. Reset breaker by pressing the button.
4. Reconnect the ac plugs.

The Inverter Output should power up. If the breaker continues to trip, turn off the 60Hz AC Inverter Power switch and contact Tesla™ for further instructions.

## Disabling the 60Hz 120 Vac Power Outlet

When power is no longer needed, make sure to turn off both the Inverter On/Off switch and the 60Hz AC Inverter Power switch. This will ensure that the power cells are not drained unnecessarily.

## Section 7 – Post Operation

### 7.1 – After Operating

When not in use, the TI5400 400Hz GPU-24 UAV ACDC should be covered and stored in a dry, temperature controlled area. To preserve cell life, the GPU should be periodically plugged into an ac power source as shown in figure 7.1.1. Either 60Hz or 400Hz power (see figure 7.1.2) may be used. Although the GPU is rugged and weather resistant, good general care should be taken to maximize the GPU's life, therefore, protect the unit from the elements and man-made hazards whenever possible. The TI7000-083 Rain/Dust Cover is recommended in wet and dust prone environments and will add a level of protection to the internal circuitry. See Section 9 under Optional Accessories.

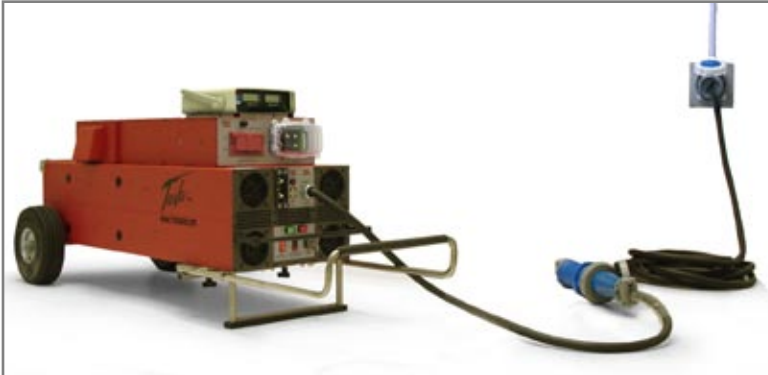

Figure 7.1.1 – TI5400 400Hz GPU-24 UAV ACDC attached to a 3-Phase 60Hz 208 Vac outlet

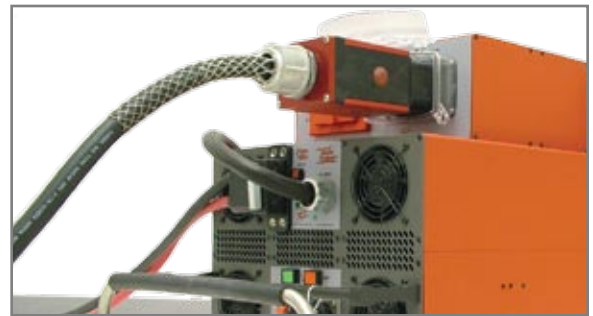

Figure 7.1.2 – 400Hz 3-Phase 200 Y 115 Vac



### 7.2 – Power Cell Recharging

The GPU has an intelligent recharging system that will enable it to rapidly recharge when connected to an ac power source. If the unit's power cells become fully discharged, the unit should be recharged within 24 hours to ensure maximum life and performance. Under normal circumstances a minimum of 12 minutes will be required to fully recharge the unit. Please refer to Section 5.1 under Unit Charging for more information.



# Section 8 – Unit Care and Maintenance

## 8.1 – Unit Care

 <b>WARNING</b>	Severe injury or death from electrical shock may occur if either the user or the TI5400 400Hz GPU-24 UAV ACDC is wet while operating the unit with an ac power source attached.
 <b>CAUTION</b>	The use of unapproved or modified ac line cable or input plug may damage the unit. Do not use any type of ac voltage converter.

### Avoid Prolonged Exposure to Extremely Damp Environments

Be sure to disconnect ac power from ac source if the TI5400 400Hz GPU-24 UAV ACDC has come into contact with water. If the AC Input Circuit Breaker has tripped due to water infiltration, allow the unit to dry out before attempting to reset the circuit breaker. Cover the unit to prevent water infiltration. If the unit is operated in extremely damp condition, it should be stored in an environmentally controlled building when not in use.



### Keep Unit Plugged into AC Power Source When Not in Use

To maximize the life of the power cells and to ensure that the unit is always ready for use, periodically plug the unit into ac power. There is no risk of damage from overheating or overcharging. See Section 5.2 for more information.

### Protect Cables from Damage

Do not cut, crush or drag the input or output power cables when handling the unit. Always inspect cables prior to use. If no damage is evident, proceed to the next step. If damage is evident, contact Tesla™ Customer Service. Do not attempt to use any other type of power cables other than the cables supplied with your unit.



## 8.2 – Normal Function Test Procedures

This section involves with “normal function” test procedures, and includes steps necessary to ensure that the TI5400 400Hz GPU-24 UAV ACDC is operating within specified parameters prior to every use. A digital multimeter (an example is shown in Figure 8.2.1) capable of measuring dc and ac voltage and resistance will be required to perform some of the tests. These functional test procedures should become routine.

### Check Unit for Evidence of Damage

Check for dents, punctures, case distortion or misalignment, and cracked or loose connectors. If no damage is evident, proceed to the next step. If damage is evident, contact Tesla™ Industries, Inc.



Figure 8.2.1 – Digital Multimeter

TESLA™ INDUSTRIES, INCORPORATED  
101 CENTERPOINT BLVD.  
CENTERPOINT INDUSTRIAL PARK  
NEW CASTLE, DELAWARE 19720  
PHONE: (302) 324-8910 FAX: (302) 324-8912  
Website: [www.teslaind.com](http://www.teslaind.com) Email: [Tesla1@teslaind.com](mailto:Tesla1@teslaind.com)



### CAUTION

Make sure the TI5400 400Hz GPU-24 UAV ACDC is disconnected from any ac power sources.



### CAUTION

Damage may occur if an unapproved or modified ac line cable or input plug is attached to the GPU. Do not use any type of ac voltage converter.

Unplug both the 60Hz and 400hz AC Input Cables from power. Additionally, disconnect all output connections (400Hz AV Output, DC Output, 60Hz Inverter Outlet, etc.).

### Checking Unit Internal Resistance (Testing for Shorts)

It is essential to test for shorts to detect any problems with the GPU. First, set the digital multimeter to measure  $\Omega$  or “resistance.” Next, test to see if both terminals are isolated from the chassis ground and the line ground using the steps in Figure 8.2.2. In each case, a reading of greater than 10 M $\Omega$  will assure no short exists.

### Testing the 400Hz AC Input Receptacle

Touch the black lead of the multimeter to an exposed metal area on the chassis (e.g. the telescopic handle frame). Next, touch the red lead of the multimeter to the neutral pin of the 400Hz AC Input Receptacle (see figure 8.2.2). The multimeter should read zero - less than 1  $\Omega$ . If this is not the case, please contact Tesla™ for further instruction.

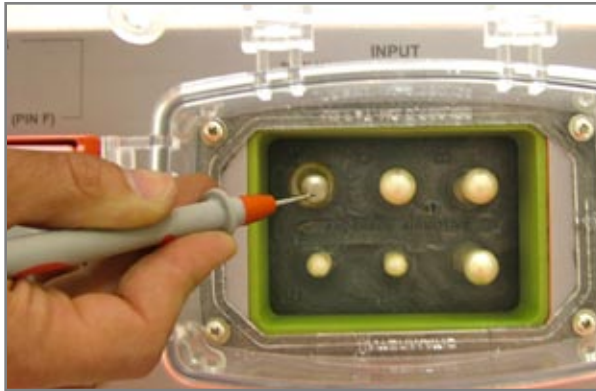

Figure 8.2.2 – 400Hz AC Input Receptacle (Neutral pin under test)

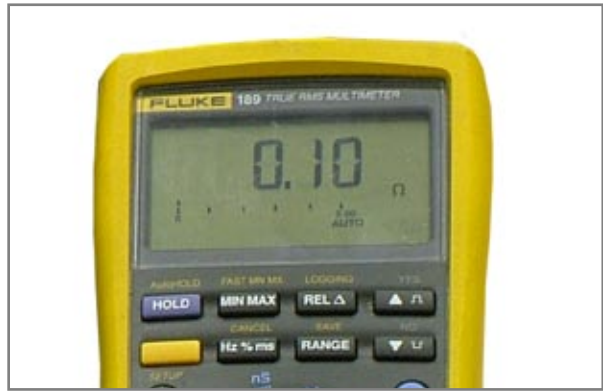

Figure 8.2.3 – Multimeter Reading Continuity (good connection)

### Testing between the 400Hz Neutral Pin and the DC Output Receptacle

Keep the Red lead of the multimeter on the 400Hz AC Input Receptacle as shown in figure 8.2.2. Next, touch the Black lead of the multimeter to the negative pin of the DC Output Receptacle as seen in figure 8.2.4. The meter should read about 2.0 M $\Omega$ . Do the same for the positive pin as seen in figure 8.2.5. The meter should read open circuit.



Figure 8.2.4 DC Output Receptacle - Negative Pin



Figure 8.2.5 DC Output Receptacle - Positive Pin

## 60Hz AC Input Receptacle

### Verifying Connection between the Chassis and 60Hz Neutral Connection

Touch the black lead of the multimeter to an exposed metal area on the chassis. Next, touch the Red lead of the multimeter to the neutral pin of the 60Hz AC Input Receptacle (shown in figure 8.2.7). The multimeter should read nearly zero ohms.



Figure 8.2.6 – Multimeter Reading Continuity (good connection)

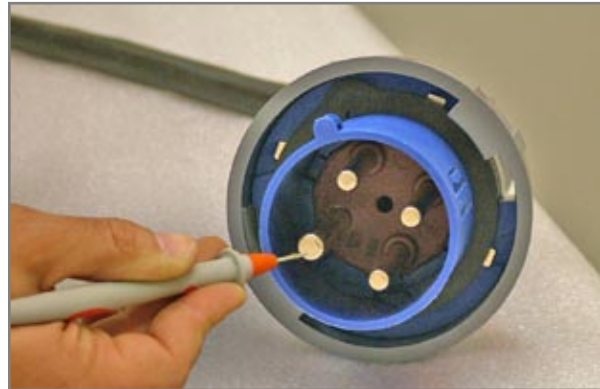

Figure 8.2.7 – 400Hz AC Input Receptacle (Ground pin under test)

### Testing between the 60Hz Neutral Connection and the DC Output Receptacle

Keep the Red lead of the multimeter on the 60Hz AC Input Receptacle as shown in figure 8.2.7. Next, touch the Black lead of the multimeter to the negative pin of the DC Output Receptacle as seen in figure 8.2.8. The multimeter should read 2 MΩ (shown in figure 8.2.10). Do the same for the positive pin as seen in figure 8.2.9. The meter should read open circuit (shown in figure 8.2.11).



Figure 8.2.8 DC Output Receptacle - Negative Pin



Figure 8.2.9 DC Output Receptacle - Positive Pin



Figure 8.2.10 – Multimeter Reading 2 MΩ



Figure 8.2.11 – Multimeter Reading Open Circuit

## Testing between the Chassis and the DC Output Receptacle

Place the red lead of the multimeter on one of the DC Output Receptacle screws as shown in figures 8.2.12 and 8.2.14. Next, touch the black lead of the multimeter to the negative pin of the DC Output Receptacle (see figure 8.2.12). The meter should read about 2.0 M $\Omega$  (see figure 8.2.12). Do the same for the positive pin (see figure 8.2.14). The meter should read open circuit (shown in figure 8.2.11).



Figure 8.2.12 DC Output Receptacle - Negative Pin

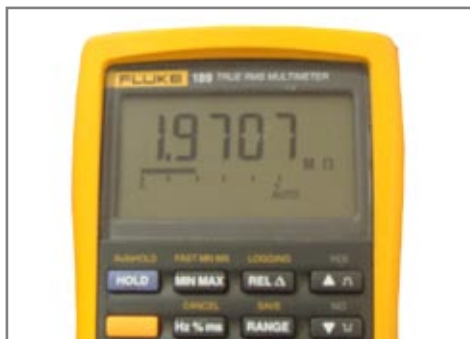

Figure 8.2.13 – Multimeter Reading Nearly 2.0 mega ohms (good connection)



Figure 8.2.14 DC Output Receptacle - Positive Pin

## Plugging in the Power Cable

Be sure to use only Tesla™ approved power cables when connecting the GPU to an ac power source. The TI5400 400Hz GPU-24 UAV ACDC comes with a built-in 60Hz AC Power Cable and detachable 400Hz AC Power Cable. Before plugging in either cable, set both AC Input Circuit Breakers to the “OFF” position (shown in figures 8.2.15 and 8.2.16).



Figure 8.2.15 400Hz AC Input Circuit Breaker (set to “OFF” position)



Figure 8.2.16 60Hz AC Input Circuit Breaker (set to “OFF” position)

## Checking the Unit for Charge State

After the unit has charged for at least 12 minutes the user should check the charge state. Press the “Push to Test” button to verify that the power cells are fully charged (see figure 6.2.2). Under a full charge the Capacity Meter will show a single green LED. See Section 6.2 for more details.



## Checking DC Voltage at DC Output Receptacle Pins



### NOTE

These tests are only necessary if the DVAM (Digital Volt/Amp Meter) is not operational.

Before making a voltage measurement, the DC Output “ON” Button needs to be turned on. This will close the contactor and connect the power cells to the DC Output Receptacle. Next, set your digital multimeter to measure DC voltage. Place the red lead of the multimeter on the positive post of the DC Output Connector (marked with the + symbol) (see figure 8.2.16). Next, place the black lead on the negative post of the DC Output Connector (marked with the – symbol).

The multimeter display should read approximately 30.25 Vdc ( $\pm 0.05$  Vdc) while running on ac power with power cells fully charged (see Figure 8.2.17). The multimeter display should read approximately 23 to 26 Vdc without ac power.



Figure 8.2.16 – Measuring voltage on DC Output Receptacle



Figure 8.2.17 – Multimeter reading typical power cell voltage (with AC power)

## Function Test Complete

Once the TI5400 400 HZ GPU-24 UAV ACDC has fully passed function test procedures, the GPU should be plugged into ac power and remain plugged in until required for use.

## 8.3 – Unit Servicing

The TI5400 400 HZ GPU-24 UAV ACDC is a maintenance-free, sealed unit. No repairs except those found in section 8.5 are authorized outside of Tesla™. Warranty will be voided if unit is tampered with in any way including any damage to the WARRANTY VOID stickers located on the case (see Figure 8.3.1 below). If the unit requires maintenance, please contact Tesla™ Customer Service at (302) 324-8910. A Repair Request Form can be found in the back of this manual.



Figure 8.3.1 – Warranty Void stickers on the front and back of unit.

## 8.4 – Packaging and Shipping

Ensure proper packaging when returning the GPU. The best method for transport is to utilize the optional TI5400 400 HZ GPU-24 UAV ACDC Shipping Case (see Section 9.2). If the Shipping Case is not available, pack the GPU in a box with at least 6-inches of clearance on all sides (be sure to enclose the Repair Request Form). To guarantee that the unit remains centered within the box, do not use loose packing materials such as packing peanuts. Instead, wrap the unit tightly in foam or other dense material until it fits snugly in the box. Seal the box on all sides and return it to Tesla™ at the address listed below. Please contact Tesla™ Customer Service at (302) 324-8910 with any questions or concerns.

TESLA™ INDUSTRIES, INCORPORATED  
109 CENTERPOINT BLVD.  
CENTERPOINT INDUSTRIAL PARK  
NEW CASTLE, DELAWARE 19720  
PHONE: (302) 324-8910 FAX: (302) 324-8912  
Website: [www.teslainsd.com](http://www.teslainsd.com) Email: [Tesla1@teslainsd.com](mailto:Tesla1@teslainsd.com)



Figure 8.4.1 Tesla™ TI5400 GPU-24 400Hz UAV ACDC Shipping Case (Optional)

## 8.5 – Storage

If unit can not be connected to ac power while in storage, we recommend to charge the unit once a year. The shelf-life of 12 months is due to the battery /cells inside the unit. We guarantee the unit will hold 80% of its charge for a period of 12 months without being recharged. When the GPU's leave the facility, they are fully charged and if they are to go into storage (without being used), they will maintain 80% of their charge after 12 months. The life expectancy of the units, if maintained properly, is 5 to 7 years.

## Section 9 – Optional Accessories

### 9.1 – Rain/Dust Cover (TI7000-083)

The TI5400 400 Hz GPU-24 UAV ACDC has an optional Rain/Dust Cover to allow for safe operation from light rain, fog and sand. This heavy vinyl cover fastens with Velcro® straps for a secure fit. To order a Rain/Dust Cover or any of the Tesla™ accessories shown here, please contact Tesla™ Customer Service at (302) 324-8910.



Figure 9.1.1 – Rain/Dust Cover

### 9.2 – Shipping Case (TI7000-069)

An optional shipping and storage case is available for the TI5400 400 Hz GPU-24 UAV ACDC. It is a reinforced hard case, specifically designed to house the unit and unit accessories (power cables, manual, etc.). The interior of the case and lid is lined with durable foam to protect the unit. Additionally, the lid is fitted with two locking mechanisms and recessed handles for easy shipping and transport.



Figure 9.2.1 – Shipping Case



### 9.3 – Customized Cables

Tesla™ Industries can customize cables to cater to our customers' specific needs. Our connectors and cable assemblies are warranted for 2 years. Custom cables and cable assemblies can be ordered through the Tesla™ Customer Service.

### 9.4 – Cobra™ DC Aviation Plug Replacement Contacts and Tools

Cobra™ DC Plugs provide reliable high-power connections up to 3000 amps — even in the harshest conditions. A rugged combination of advanced composite materials and corrosion-resistant alloys make each plug maximized for durability and connectivity. To extend the life of the Cobra™ connectors included with your unit, replacement contacts, posts, noses and tools can be ordered through the Tesla™ Customer Service.



Figure 9.4.1 – Cobra™ Aviation Plug



Figure 9.4.2 – Cobra™ 400Hz Aviation Plug



Figure 9.4.3 – Cobra™ Aviation Plug Contact Replacement & Tools

### 9.5 – Tow Cart

The Tesla™ TI2000-155 is a custom stainless steel cart designed especially to hold Tesla's™ TI5400 Series Storage Cases. The cases can be secured directly to the cart, making the TI2000-155 the safest way to support and transport any TI5400 model out in the field and through hangars and flight lines.

You can operate the TI5400 GPU without ever removing it from the cart – simply remove the lid of the Storage Case for access to the entire unit. And you can rest assured that Tesla™ stands behind the Tow Cart with a team of customer service professionals and a 2-year warranty.

The TI2000-155 features Run-Flat or Pneumatic all-terrain tires, manual rear disc brakes, tow handle with handle release, front wheel steering via tow handle, and four stainless steel compression draw latches to secure case to cart.



Figure 9.4.1 – TI2000-155 Tow Cart

# Section 10 – Frequently Asked Questions

## **1. What are the advantages of owning a Tesla™ Ground Power Unit?**

Tesla™ Ground Power Units are multi-functional systems that are ideal for support of 24 Vdc vehicles and aircraft and their electronics/avionics. These units are available in different sizes and capacities, are man-portable, maintenance free and provide pure, dc power in a completely safe package. Tesla™ GPUs are perfect for maintenance support at a main facility or in remote locations. They will also provide 28.5 or 30.25 Vdc when the system is connected to the appropriate AC source. Tesla™ GPUs are remarkably smaller and lighter than most ground power units on the market today. They are safe for storage and for transport aboard an aircraft. The technology can be upgraded on certain models. And, as always, there are no HAZMAT or disposal issues with any of our GPUs.

## **2. How does a Turbo Start™ work?**

The Turbo Start™ combines state-of-the-art power conversion electronics with our proprietary “dry cell” batteries. The system’s electronics incorporate an intelligent charging system for the cells as well as an ac to dc converter. The cells are ideal for this application as they are non-spillable, lead dry-cells that are sealed, maintenance-free and safe for air transport.

## **3. Do the cells have memory?**

No. The user can plug the TI5400 400 Hz GPU-24 UAV ACDC into either a 60 Hz or 400 Hz ac power source for charging regardless of the unit’s state of charge. The intelligent charging system will rapidly recharge the cells and then switch to trickle mode to maintain a full charge.

## **4. How are Ground Power Units used in aviation support?**

A Tesla™ GPU can be used to start any aircraft that uses a 24 volt system and can provide reliable ground power. GPUs can be connected to a 60 Hz or 400 Hz ac power source to produce 28.5 or 30.25 Vdc for testing and troubleshooting avionics and communications systems without depleting the charged cells.

## **5. How much DC power will the TI5400 400 Hz GPU-24 UAV ACDC provide?**

The TI5400 400Hz GPU-24 UAV ACDC will provide regulated 30.25 Vdc Output Ground Power up to 400 continuous amps with an ac power source and 3000 peak starting amps directly from the internal cells. The 400 Hz Output will provide up to 30 amps of filtered power, and the Inverter will provide 120 Vac 60Hz at up to 20 amps.

## **6. How many engine starts will the TI5400 400Hz GPU-24 UAV ACDC provide until depleted?**

If the GPU is not allowed time to back-charge after an engine start, it should provide approximately 6 to 8 starts before it needs to be plugged in to an ac power source for recharging.

**7. How long does this unit stay charged?**

When not plugged into an ac power source, the GPU will retain 80% of its capacity after one year of storage. However, the GPU should never be allowed to fully discharge.

**8. How do I check the status of the charge?**

Press the “Push To Test” button on the unit’s faceplate. A fully charged unit will have one green LED light showing. See Section 5.3 for further information.

**9. Why does my LED flicker when the unit is plugged in?**

Under a full charge, some units will show a single pulsating green LED. See Section 6.2 under GPU Charging for more information.

**10. Why does the cooling fan run continuously when the TI5400 400HZ GPU-24 UAV ACDC is connected to AC power? Why does the cooling fan slow down?**

The cooling fan speed varies to regulate the temperature of the internal circuitry when plugged into an AC power source.

**11. How do you prolong the life of the TI5400 400HZ GPU-24 UAV ACDC’s power cells?**

Plug the GPU into an ac power outlet when not in use. Users who periodically plug the unit into ac power can expect to get approximately 5 to 7 years from their cells before replacement. See Section 7.1 for more information about general care and maintenance.

**12. What is included with my TI5400 400HZ GPU-24 UAV ACDC?**

The GPU comes with a Tesla™ approved 400 Hz aircraft power cable, a 25 ft DC aircraft cable with DC plug, a 60 Hz extension cable, a TI3100A DVAM, a user manual and a limited, two-year warranty.

**13. Is the TI5400 400HZ GPU-24 UAV ACDC waterproof?**

The GPU is water-resistant, but not waterproof. See Section 1.3 for further information.

**14. Are there any HAZMAT or disposal issues?**

No. Tesla™ will reclaim all battery cells for disposal. Contact Tesla™ for more information.

# Section 11 – Troubleshooting

## 1. When I plug the GPU into AC power it does not charge.

While charging, at least one green LED should be illuminated on the Charge Status Meter. If this is not the case, verify that the outlet has proper line voltage.

### 60 Hz 3-phase ac power

#### Is there ac line voltage at the outlet?

No: Consult an electrician.

Yes: Proceed to the next step.

#### Is the 60 Hz AC Input Circuit Breaker on?

No: Turn the breaker ON.

Yes: Contact Tesla™ Industries, Inc.

The unit should power up automatically. If the unit is still not charging, contact Tesla™ Industries for further instructions.

### 400 Hz 3-phase ac power at filter

#### Is there ac line voltage at the outlet?

No: Consult an electrician.

Yes: Proceed to the next step.

Verify that the 400 Hz 3-phase ac cable is good. Disconnect the cable from both the GPU and ac power. Set your multimeter to measure  $\Omega$  (resistance) and check continuity between the connector pins according to the chart (see Figures 11.1.1 and 11.1.2). The multimeter should read nearly zero. A broken connection will show an open circuit (see Figure 11.1.3).

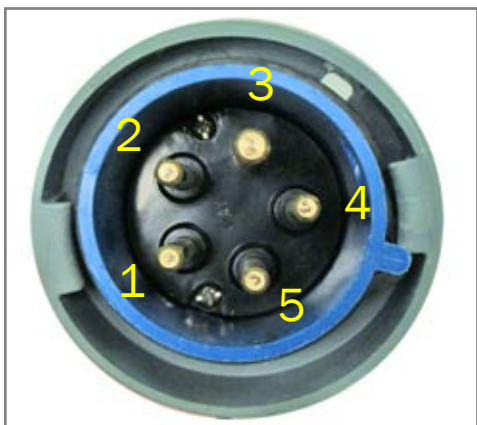

Figure 11.1.1 – 400Hz 3-Phase AC Plug

- 1 = B
- 2 = A
- 3 = GROUND
- 4 = N
- 5 = C

Pins F and E are not in use



Figure 11.1.2 – 400Hz 3-Phase Aviation Plug

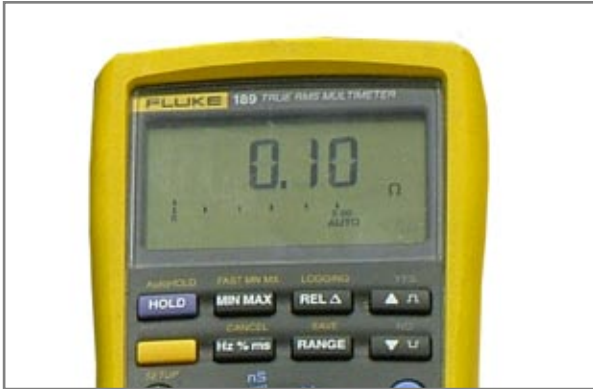

Continuity (good connection)



Open Circuit (bad connection)

Figure 11.1.3 Multimeter showing continuity and open circuit between connector pins

**Is the 400Hz 3-Phase AC cable good?**

No: Contact Tesla™ Industries, Inc.

Yes: Proceed to the next step.

**Is the 400Hz AC Input Circuit Breaker on?**

No: Turn the breaker ON

Yes: Contact Tesla™ Industries, Inc.

The unit should power up automatically. If the GPU is still not charging, contact Tesla™ for further instructions.

**NOTE**

The TI5400 GPU-24 is equipped with a charger temperature sensor that automatically disables ac and charging functions when the internal temperature reaches 150 °F (65 °C). This protects the unit from overheating and damage. If the unit shuts down, move the unit into a cooler environment such as shade or air conditioning when possible. Perform a full function test prior to use after the unit has been allowed to cool.

**2. When I plug in the GPU, the Air Exhaust Fans do not turn on.**

The internal cooling system of the TI5400 GPU-24 has been designed to efficiently regulate unit temperature regardless of load. If the fans are not on, but the Capacity Meter displays a charge, this may indicate that the Air Exhaust Fans have failed. Disconnect power immediately and contact Tesla™ for further instructions.

**3. The GPU has power, but the cells are not charging.**

Under normal circumstances, the unit requires 12 minutes to fully recharge after a complete discharge. If the unit is not fully charged after 12 minutes, the power cells may need to be replaced. Return the unit to Tesla™ for evaluation and maintenance.

**4. The unit is charged, but the “Push to Test” button does not seem to work.**

If the unit is fully charged, the internal temperature sensor may have tripped. This happens any time the “Push to Test” button has been pressed for more than 5 seconds. Allow 5 minutes for cooling before pushing the button again. If the “Push to Test” button still fails to activate the Capacity Meter, return the unit to Tesla™ for evaluation and maintenance.

**5. The unit is charged, but I’m not getting any voltage from the DC Output Receptacle.**

The power cells on the TI5400 GPU require a minimum charge level to function properly. If one or more red LEDs are illuminated on the Capacity Meter the GPU may need recharging. If this is not the case, verify that the green DC Output “ON” button is illuminated.

**Is the DC Output ON Button active (button illuminated)?**

No: Press the DC Output ON Button.

Yes: Contact Tesla™ Industries, Inc.

The DC Output Receptacle should read between 24.0 V and 27.6V. If the unit is still not putting out any voltage, contact Tesla™ Industries for further instructions.

**6. The 400Hz AC Input is connected and the GPU is running, but I’m not getting any voltage from the 400Hz AC Output Receptacle.**

The 400 Hz AC Output Receptacle is connected directly to the 400 Hz AC Input Receptacle via the 400 Hz Surge/EMC Filter and 400 Hz Output Circuit Breaker. As a result, the user only needs to set the 400 Hz Output Circuit Breaker to transfer power.

**Is the 400Hz Output Circuit Breaker set to the “ON” position?**

No: Turn on the 400Hz Output Circuit Breaker.

Yes: Contact Tesla™ Industries, Inc.

The 400Hz AC Output Power Indicator should illuminate, indicating that the 400Hz AC Output Receptacle is live. If the GPU is still not putting out any voltage, and the Output Power Indicator is not lit, contact Tesla™ Industries for further instructions.



### 7. When I plug my device into the 60Hz 120 Vac Power Outlet, I don't get any power.

The 60Hz 120 Vac Power Outlet produces voltage directly from the power cells. Therefore, the 120Vac Outlet should function regardless of whether the GPU is plugged in. Before proceeding, make sure the batteries have a sufficient charge. If the Power Outlet is not on, verify that the 60Hz AC Inverter Power Switch is in the "ON" position. The red LED next to the Inverter Power Switch should be on (see figure 11.1.4).

#### Is the 60Hz AC Inverter Power Switch On (LED illuminated)?

No: Turn on the 60Hz AC Inverter Power Switch.

Yes: Proceed to the next step.



Figure 11.1.4 60Hz AC Inverter Power set to "ON" position (LED illuminated)



Figure 11.1.5 Inverter Display Panel and On/Off Switch turned on and active.

#### Is the Inverter On/Off Switch in the "I" position (see figure 11.1.5)?

No: Turn on the Inverter On/Off Switch.

Yes: Proceed to the next step.

#### Is the Inverter Display Panel LCD on (see figure 11.1.5)?

No: Contact Tesla™ Industries, Inc.

Yes: Proceed to the next step.

#### Is the Inverter Output Circuit Breaker tripped (see figure 11.1.6)?

No: Proceed to the next step.

Yes: Push the breaker in to reset.

#### Is the 60Hz AC Power Outlet LED illuminated (see figure 11.1.7)?

No: Press the "Reset" button on the Outlet.

Yes: Proceed to the next step.





Figure 11.1.6 – 60Hz AC Output Circuit Breaker (push to reset)



Figure 11.1.7 – 60Hz AC Power Outlet “ON” (green LED illuminated)

If the green LED on the front of the 60Hz AC Power Outlet is illuminated the Outlet should be live. If the LED does not light after pressing the “Reset” button, contact Tesla™ Industries for further instructions.

### 8. Can I make repairs to the unit?

During the warranty period, the unit can only be repaired by Tesla™ Industries for the warranty to remain in effect. Regardless, we strongly recommend allowing Tesla™ to repair any unit as we will analyze the complete system and re-calibrate it.

### 9. How do I get my TI5400 400Hz GPU-24 UAV ACDC serviced?

If the unit needs to be returned for repairs, please contact Tesla™ Customer Service by phone at (302) 324-8910, or by email at [tesla1@teslaind.com](mailto:tesla1@teslaind.com) and a representative will explain the return process. For your convenience, a Repair Request Form can be found in the back of this manual. The form can also be found online at [www.teslaind.com](http://www.teslaind.com).

### 10. What type of maintenance does the TI5400 400Hz GPU-24 UAV ACDC require?

Although the unit is maintenance-free, it is recommended to keep the GPU plugged in when not in use. This will greatly extend the life of the cells. Keep unit in a well ventilated, climate-controlled environment while charging. Always keep the vent areas clean and free of debris.

# Section 12 – Performance Data

## 12.1 – Purpose

This chapter provides performance data for the TI5400 400HZ GPU-24 UAV ACDC. This information will allow the user to obtain maximum performance and life from the unit. Regular referral to this chapter is recommended to:

1. Gain knowledge of the unit's performance characteristics to anticipate unexpected conditions or extreme operational requirements.
2. Readily identify situations requiring maximum performance.



### NOTE

The information provided in this chapter is most useful when anticipating operations under unknown conditions or environmental extremes. The data can also be used to establish local operating procedures and to maximize the unit's life.

## 12.2 – Explanation of Data

The data presented covers the full range of operating conditions and expected performance. In each area of performance, temperature effects and dc electrical load demands in relation to ground power support requirements are presented. In some cases, data is presented conservatively. In all cases, performance data presented is within the applicable limits of the TI5400 400HZ GPU-24 UAV ACDC. Any attempt to exceed maximum recommended limits may cause the unit to malfunction and may cause permanent damage.

## 12.3 – General Conditions

In addition to the specific conditions, the following general condition is applicable to the performance data Variations in Aircraft – Power demand differences between individual aircraft of the same make and model are known to exist due to variations in dc electrical system efficiency. These differences, however, are considered insignificant and are not accounted for individually.

## 12.4 – Definition of Abbreviations

Unless otherwise indicated, the abbreviations defined in Section 2.2 will be applicable to all charts and graphs in this chapter.

12.5 - Performance Graphs

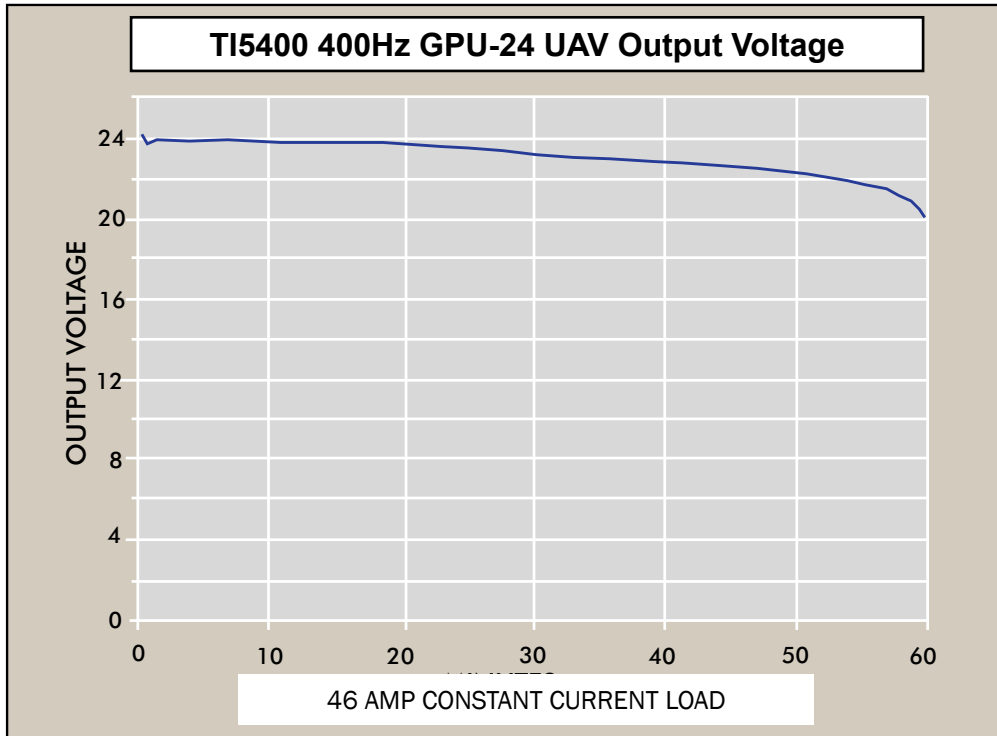

12.5.1 Output voltage versus discharge time

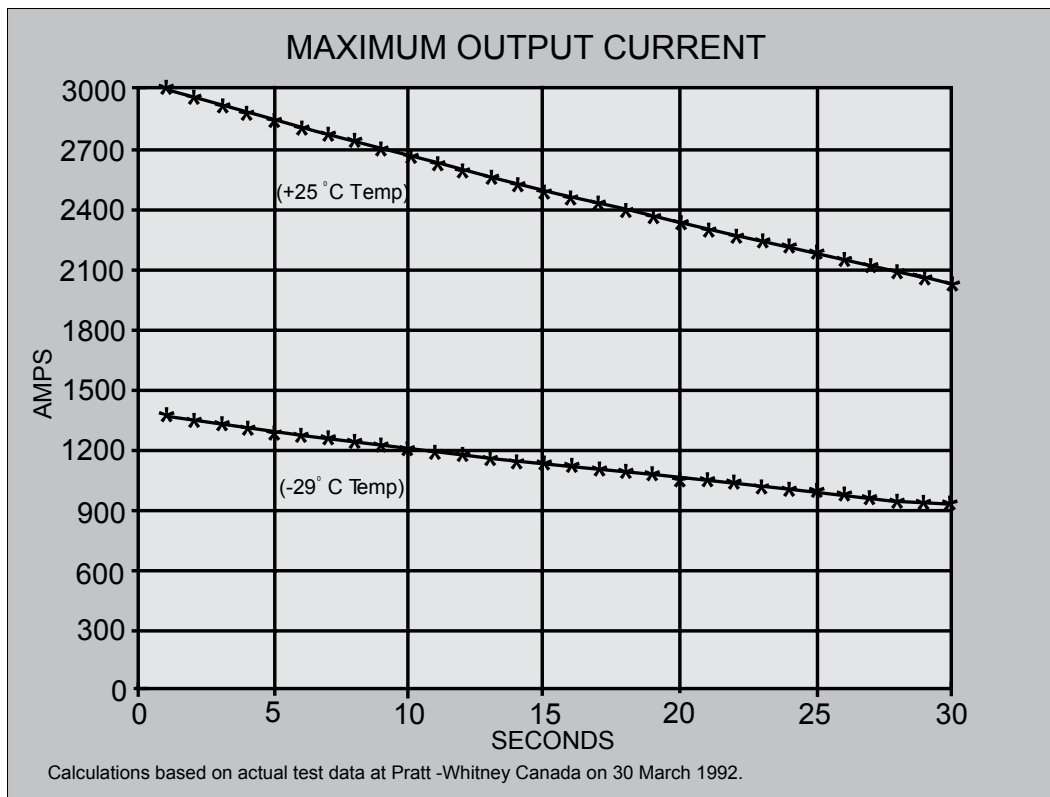

12.5.2 Maximum output current versus time

## 12.6 – Temperature Conversion Chart

°C	°F	°C	°F	°C	°F	°C	°F
-60.0	-76.0	-27.0	-16.6	6.0	42.8	39.0	102.2
-59.0	-74.2	-26.0	-14.8	7.0	44.6	40.0	104.0
-58.0	-72.4	-25.0	-13.0	8.0	46.4	41.0	105.8
-57.0	-70.6	-24.0	-11.2	9.0	48.2	42.0	107.6
-56.0	-68.8	-23.0	-9.4	10.0	50.0	43.0	109.4
-55.0	-67.0	-22.0	-7.6	11.0	51.8	44.0	111.2
-54.0	-65.2	-21.0	-5.8	12.0	53.6	45.0	113.0
-53.0	-63.4	-20.0	-4.0	13.0	55.4	46.0	114.8
-52.0	-61.6	-19.0	-2.2	14.0	57.2	47.0	116.6
-51.0	-59.8	-18.0	-0.4	15.0	59.0	48.0	118.4
-50.0	-58.0	-17.0	1.4	16.0	60.8	49.0	120.2
-49.0	-56.2	-16.0	3.2	17.0	62.6	50.0	122.0
-48.0	-54.4	-15.0	5.0	18.0	64.4	51.0	123.8
-47.0	-52.6	-14.0	6.8	19.0	66.2	52.0	125.6
-46.0	-50.8	-13.0	8.6	20.0	68.0	53.0	127.4
-45.0	-49.0	-12.0	10.4	21.0	69.8	54.0	129.2
-44.0	-47.2	-11.0	12.2	22.0	71.6	55.0	131.0
-43.0	-45.4	-10.0	14.0	23.0	73.4	56.0	132.8
-42.0	-43.6	-9.0	15.8	24.0	75.2	57.0	134.6
-41.0	-41.8	-8.0	17.6	25.0	77.0	58.0	136.4
-40.0	-40.0	-7.0	19.4	26.0	78.8	59.0	138.2
-39.0	-38.2	-6.0	21.2	27.0	80.6	60.0	140.0
-38.0	-36.4	-5.0	23.0	28.0	82.4	61.0	141.8
-37.0	-34.6	-4.0	24.8	29.0	84.2	62.0	143.6
-36.0	-32.8	-3.0	26.6	30.0	86.0	63.0	145.4
-35.0	-31.0	-2.0	28.4	31.0	87.8	64.0	147.2
-34.0	-29.2	-1.0	30.2	32.0	89.6	65.0	149.0
-33.0	-27.4	0.0	32.0	33.0	91.4	66.0	150.8
-32.0	-25.6	1.0	33.8	34.0	93.2	67.0	152.6
-31.0	-23.8	2.0	35.6	35.0	95.0	68.0	154.4
-30.0	-22.0	3.0	37.4	36.0	96.8	69.0	156.2
-29.0	-20.2	4.0	39.2	37.0	98.6	70.0	158.0
-28.0	-18.4	5.0	41.0	38.0	100.4	71.0	159.8

Figure 12.6.1 – Temperature conversion from Celsius to Fahrenheit.

# Glossary

Avionics	A combination of the words “aviation” and “electronics,” avionics comprises electronic systems for use on aircraft such as communications, navigation, and the display and management of multiple systems.
Digital Multimeter	A digital multimeter (DMM, DVAM, DVOM) displays the measured value in numerals, and may also display a bar of a length proportional to the quantity being measured. It is an electronic measurement device that combines several functions into one unit. A standard multimeter may include features such as the ability to measure voltage, current and resistance.
Ground Fault	A condition in which an imbalance in electrical current occurs due to a faulty connection path such as a current leakage through the body of a person who is grounded and accidentally touching the energized part of the circuit.
Intelligent Recharging	A system which continuously monitors the cell’s charge state and automatically adjusts the recharge rate to maximum performance and minimize cell degradation.
Memory Effect	If a NiCd battery is only partially discharged then recharged many times, it will begin to “remember” the level it was discharged to and will no longer fully recharge. The TI5400 GPU’s internal cells do not have a memory effect.
Monolithic Dry-Cell	A one-piece battery that is hermetically sealed and designed for maintenance-free operation.
Single Phase Power	In electrical engineering, single-phase electric power refers to the distribution of alternating current electric power using a system in which all the voltages of the supply vary in unison.
Lead Acid Battery	A battery that uses the reaction of lead and lead oxide with sulfuric acid electrolytes to produce a voltage (e.g. a car battery).
UAV	A UAV (unmanned aerial vehicle) is an unpiloted aircraft either controlled from a remote location, or flying autonomously based on pre-programmed flight plans using more complex and dynamic automation systems.

# Repair Request Form

Please complete the information below to ensure prompt and accurate service. Include this form with the unit you are returning. Thank you.

Date of return: \_\_\_\_\_

Company name & \_\_\_\_\_  
\_\_\_\_\_  
\_\_\_\_\_

Billing address: \_\_\_\_\_  
\_\_\_\_\_  
\_\_\_\_\_

Contact person: \_\_\_\_\_

Phone #: \_\_\_\_\_ Fax #: \_\_\_\_\_

Email: \_\_\_\_\_

Purchase Order #: \_\_\_\_\_

Model #: \_\_\_\_\_ Serial #: \_\_\_\_\_

Model #: \_\_\_\_\_ Serial #: \_\_\_\_\_

Shipping method to Tesla™: \_\_\_\_\_

Description of shipping package: \_\_\_\_\_

Description of problem: \_\_\_\_\_

\_\_\_\_\_  
\_\_\_\_\_  
\_\_\_\_\_

**Return to Tesla™**

101 Centerpoint Boulevard, New Castle, DE 19720 Attention: Repair Department





**WE GET THE MILITARY STARTED!**

**Tesla™**

101 Centerpoint Blvd.  
New Castle, DE 19720 USA  
Tel: 302-324-8910  
Fax: 302-324-8912

9475 Double R Blvd., Suite 2  
Reno, NV 89521  
Tel: 775-622-8801  
Fax: 775-622-8810

[www.teslaind.com](http://www.teslaind.com) ♦ [www.tesla1.com](http://www.tesla1.com)